



INSTALLATION & OPERATING MANUAL

IGNITE XL BOLD

Models

- BXLF1200-AU
- BXLF1800-AU
- BXLF2500-AU



The product is compliant with the local electrical standards of all countries where offered for sale by Glen Dimplex and its subsidiaries.

VERSION 1

7216730100R01

TABLE OF CONTENTS

Welcome	3
Technical Specifications	6
Electrical Requirements	6
Product Dimensions	6
Package Contents	7
Installation	9
Placement	9
Preparing the Firebox for Installation	10
Installation Instructions	11
Heater Hardware Disconnect	14
Mirrored Glass Installation	15
Media Arrangement	15
Side Glass Installation	16
Front Glass Installation	16
Operation	17
General Operation	17
Hidden Touch Controls	17
Remote Operation	17
Resetting the Temperature Cutoff Switch	17
App	19
Maintenance	20
Troubleshooting	21
Wiring Diagrams	22
Warranty	23

WELCOME

Please carefully read and save these instructions.

Please record your model and serial numbers for future reference. Model and serial numbers can be found on the label located behind the front glass of your fireplace.

Model _____ MOD _____

Serial Number _____

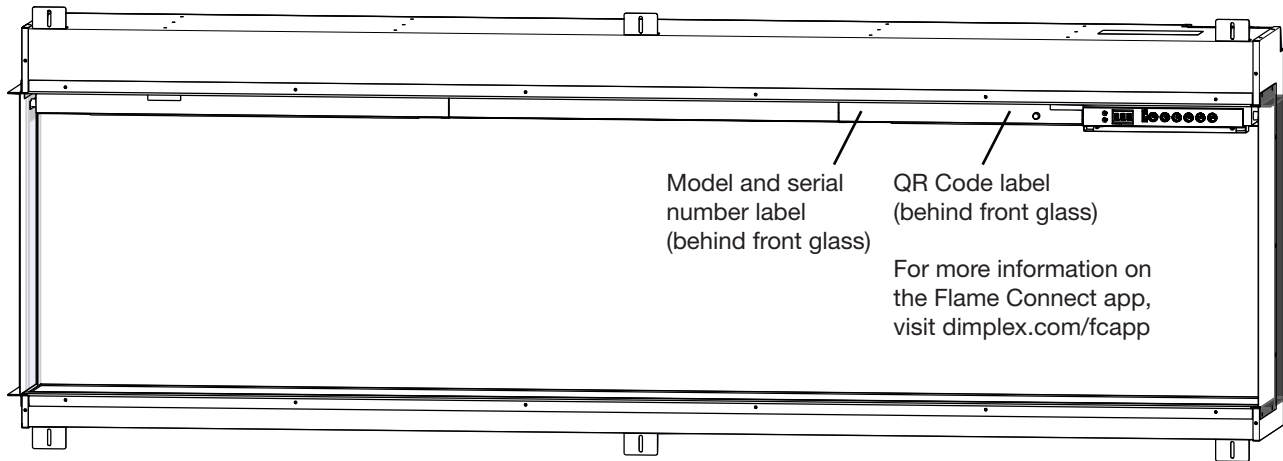

CAUTION: Read all instructions and warnings carefully before starting installation. Failure to follow these instructions may result in a possible electric shock, fire hazard and will void the warranty.

Important Safety Advice

When using electrical appliances, basic precautions should always be followed to reduce the risk of fire, electrical shock and injury to persons, including the following:

If the appliance is damaged, check with the supplier before installation and operation.

- Do not use outdoors.
- Do not use in the immediate surroundings of a bath, shower or swimming pool.
- Do not locate the appliance immediately below a fixed socket outlet or connection box.
- Do not use this heater if it has been dropped.
- Do not use if there are visible signs of damage to the heater.
- Use this heater on a horizontal and stable surface.

The appliance is not intended for use by persons (including children) with reduced physical, sensory or mental capabilities, or lack of experience and knowledge, unless they have been given supervision or instruction concerning use of the appliance by a person responsible for their safety. Children should be supervised to ensure that they do not play with the appliance. Children shall not plug in, regulate and clean the appliance or perform user maintenance.

SAVE THESE INSTRUCTIONS

WELCOME

Do not use this appliance in series with a thermal control, a program controller, a timer or any other device that switches on the heat automatically, since a fire risk exists when the heater is accidentally covered or displaced.

Ensure that furniture, curtains or other combustible material are positioned no closer than 1 meter from the appliance.

In the event of a fault disconnect the appliance.

Disconnect the appliance when not required for long periods.

The appliance must be positioned so that the plug is accessible. Check the Electrical Requirements section for more details. If the supply cord is damaged, it must be replaced by the manufacturer or service agent or a similarly qualified person in order to avoid a hazard.

Keep the supply cord away from the front of the appliance.

Warning: This appliance must be earthed.

The use of an extension lead or multi-plug adaptor is not advised when connecting this product to the mains. Connection through these devices could lead to a risk of overloading, overheating and even fire at the extension lead or adaptor due to inadequate connection quality.

This heater must be used on an alternating current supply (~) only and the voltage marked on the heater must correspond to the supply voltage.

WARNING: In order to avoid overheating, do not cover the appliance. Do not place material or garments on the appliance, or obstruct the air circulation around the appliance.

The appliance carries a DO NOT COVER warning symbol. 

This appliance is equipped with a device to control the room temperature. Do not use this appliance in small rooms when they are occupied by persons not capable of leaving the room on their own, unless constant supervision is provided.

The electrical information regarding your electric fireplace can be found on the rating label located on the top of the unit.

If you have any technical questions or concerns regarding the operation of your electric fireplace, or require service contact the relevant customer service as listed on your warranty card.

CAUTION: Do not use if the heater's mains power lead is damaged. Such use may cause a hazard. If damaged, the mains power lead must be replaced by the manufacturer or its authorised dealer.

CAUTION: Assembly, installation and repair of this heater must be carried out by Dimplex or its authorised agent.

CAUTION: We recommend that this heater is checked annually for safety by a qualified electrician.

Warning: Packaging, in particular plastic bags are NOT toys. To prevent injury or even death keep packaging away from children at all times.

CAUTION: Some parts of this product can become very hot and cause burns. Particular attention has to be given where children and vulnerable people are present.

Warning: The heater must not be located immediately below a socket-outlet.

WELCOME

CAUTION: In order to avoid a hazard due to inadvertent resetting of the thermal cut-out this appliance must not be supplied through an external switching device, such as a timer or connected to a circuit that is regularly switched on and off by the utility.

CAUTION: Ensure installation does not allow fire to be in direct contact with building vapor barrier or insulation and meets all local building code.

WARNING: To reduce the risk of fire, do not store or use gasoline or other flammable vapors or liquids in the vicinity of the heater.

Warning: Choking may be caused by swallowing small loose fuel bed media (river rocks, Ash Dust, Vermiculite) accidentally. Keep away from children all the time.

WARNING - KEEP BATTERIES OUT OF REACH OF CHILDREN

- Swallowing may lead to serious injury in as little as 2 hours or death, due to chemical burns and potential perforation of the esophagus.
- If you suspect your child has swallowed or inserted a button battery immediately call the 24-hour Poisons Information Centre on 13 11 26 (in Australia) or 0800 764 766 (in New Zealand) for fast, expert advice.
- Examine devices and make sure the battery compartment is correctly secured, e.g. that the screw or other mechanical fastener is tightened. Do not use if the compartment is not secure.
- Dispose of used button batteries immediately and safely. Flat batteries can still be dangerous.

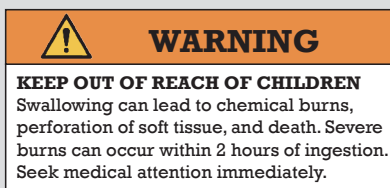

CAUTION: No obvious symptoms

Unfortunately, it is not obvious when a button or coin battery is stuck in a child's oesophagus (food pipe).

There are no specific symptoms associated with this. The child might:

- cough, gag or drool a lot
- appear to have a stomach upset or virus
- be sick
- point to their throat or stomach
- have a pain in their abdomen, chest or throat
- be tired or lethargic
- be quieter or more clingy than usual or otherwise 'not themselves'
- lose their appetite or have a reduced appetite
- not want to eat solid food/be unable to eat solid food

These types of symptoms vary or fluctuate. with the pain increasing and then subsiding.

A specific symptom to button and coin battery ingestion is vomiting fresh (bright red) blood. If the child does this seek immediate help. The lack of clear symptoms is why it is important to be vigilant with 'flat' or spare button or coin batteries in the home and the products that contain them.

TECHNICAL SPECIFICATIONS

Electrical Requirements

NOTE: A dedicated, properly fused 10 Amp circuit is required, rated for the appropriate voltage (230-240V). An isolation switch should also be incorporated in cases where the product plug is inaccessible after installation.

WARNING: Construction and wiring must comply with local building codes and other applicable regulations to reduce the risk of fire, electric shock and injury to persons.



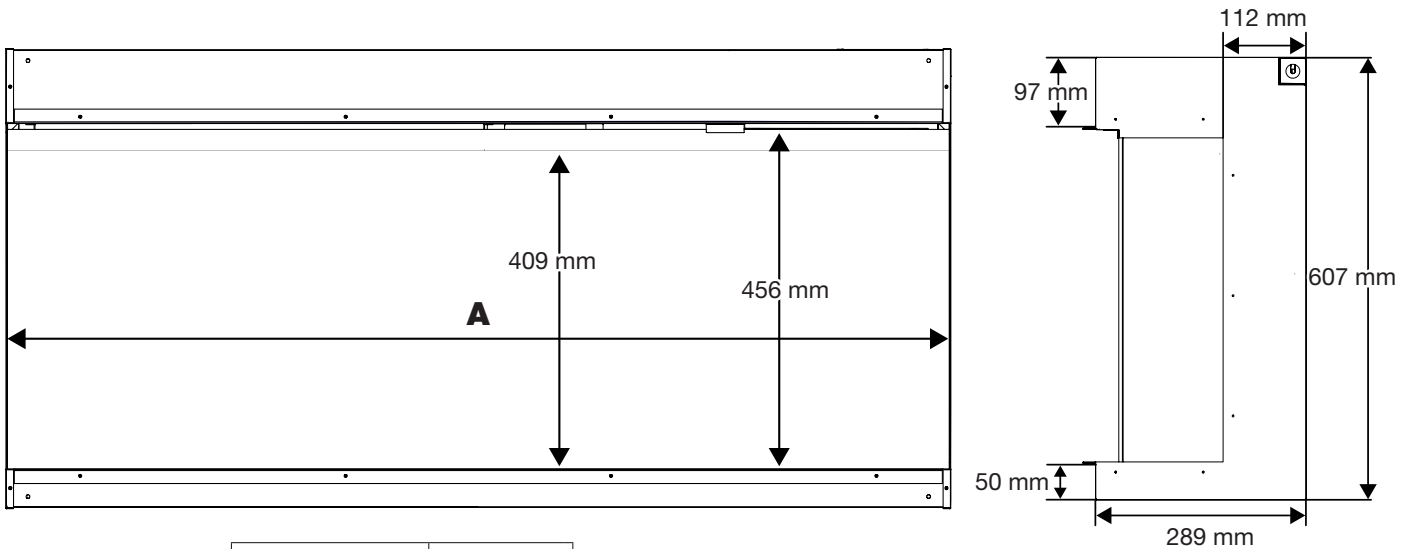

WARNING: To reduce the risk of fire, electric shock or injury to persons, always use a licensed electrician.

Product Dimensions



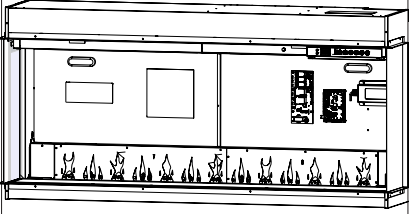
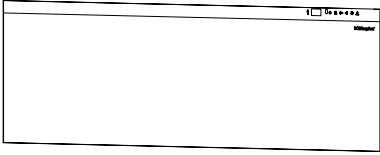
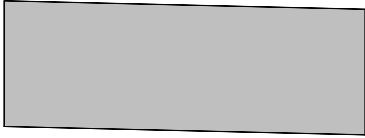

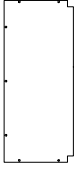
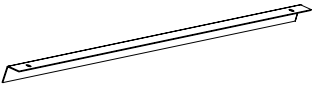

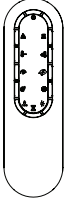

Model	A
BXLF1200-AU	1246 mm
BXLF1800-AU	1883 mm
BXLF2500-AU	2521 mm

PACKAGE CONTENTS

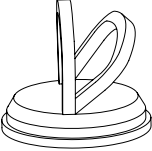
Image	Description	Quantity		
		BXLF1200-AU	BXLF1800-AU	BXLF2500-AU
	Firebox	1	1	1
	Front Glass	1	1	1
	Mirrored Glass	1	1	1
	Side Glass	2	2	2
	Closed Side Trim	2	2	2
	Mirrored Glass Bracket (lengths may vary)	1	2	2
	River Rock Media	3kg	4.5kg	6kg

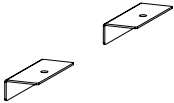
PACKAGE CONTENTS

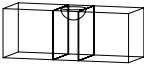
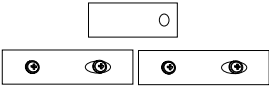
Image	Description	BXLF1200-AU	BXLF1800-AU	BXLF2500-AU
	Driftwood	6	9	11
	Remote Control	1	1	1
	User's and Installation Guide	1	1	1
 <p><i>Do not dispose of the suction cup after installation. Keep it in a secure location as it will be helpful for maintenance and service of the unit.</i></p>	Suction Cup	1	1	2
Hardware Kit				
	Mounting Brackets	4	6	6
	Front Glass Brackets	1	2	2
	1" Wood Screws	4	6	6
	Black Screws	11	18	18
	Bubble Level	1	1	1
	XLFDLINK Kit (2 brackets, 1 clip bracket & 4 screws)	1	1	1

Placement

! **NOTE:** It is recommended that the bottom of the unit be mounted between 5" (13 cm) and 40" (102 cm) from the ground to maintain an optimized viewing angle of the flame.

⚠ **WARNING:** The top of the fireplace must be installed a minimum of 24" (61 cm) from the ceiling.
The fireplace must be installed a minimum of 5" (13 cm) from the ground.

Wi-Fi

For installations where the use of the Flame Connect app is desired, ensure the fireplace is located within range of a Wi-Fi network.

Installation Recommendations for Overhanging Objects

For overhanging temperature-sensitive objects, such as a television, a mantel, or artwork, always follow the recommendations provided by its manufacturer for installation over a heater.

! **NOTE:** Using normal heat mode, surfaces 7" (18 cm) above the fireplace will not exceed 40° C, as long as installation procedures are followed and heater inlet and outlet are not obstructed.

Preparing the Firebox for Installation

! **NOTE:** For multi-unit installation, refer to instructions provided with the accessory kit (XLFXDLINK, sold separately).

1. Remove packing support brackets by removing the screws on each bracket. (Figure 1) These brackets and screws can be discarded.
2. Install the desired side trim option on each side of the firebox.
 - For closed side, remove the installed open side trim by removing 7 screws (fig 2) and reuse the screws to install closed side trim (fig 3).
3. If a permanently heat-disabled installation is desired, follow the instructions to disable the heater in the *Permanent Heat Disable* section (p. 16).
4. Carefully lay the firebox on its back and install the mounting brackets to the top and bottom of the firebox with the black screws provided. (Figure 5)

! **NOTE:** There are 4 mounting brackets for BXLF1200-AU units (Figure 6), and 6 mounting brackets for BXLF1800-AU, and BXLF2500-AU units. (Figure 7)

! **NOTE:** The mounting brackets are equipped with slots to allow small adjustments to fit the framing. Ensure all the brackets are aligned.

Figure 1

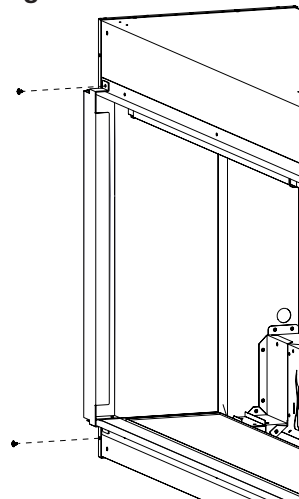

Figure 2

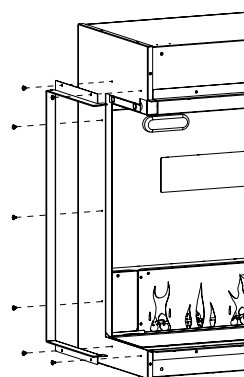

Figure 3

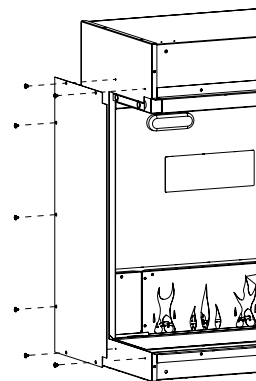

Figure 5

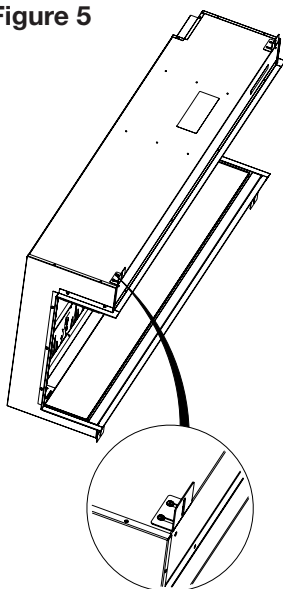

Figure 4

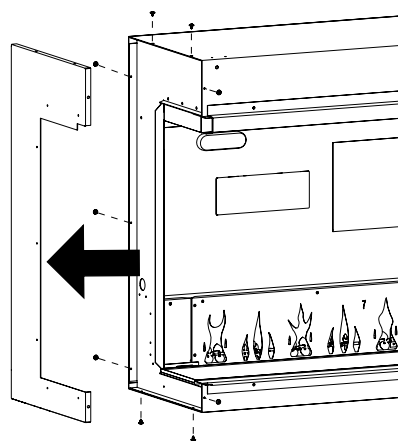

Figure 6

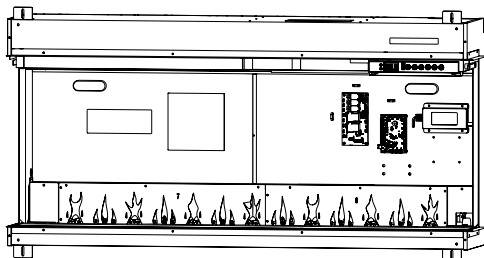
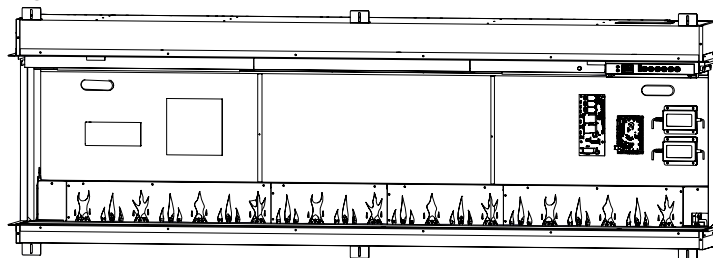

Figure 7



Installation Instructions

- ! **NOTE:** Two people are required for installation.
 - ! **NOTE:** Ensure the product is within 1m of a power outlet. Please refer to Electrical Requirements section on page 7 for more details.
1. Prepare a wall with a framed opening, following the dimensions in the table below. The dimensions are the same for front, corner, and bay installations.
- ! **NOTE:** These framing dimensions are based on installation with 1/2" drywall.

Framing Dimensions

Model	Width	Height	Depth (minimum)
	A	B	C
BXLF1200-AU	1257 mm	616 mm	295 mm
BXLF1800-AU	1895 mm		
BXLF2500-AU	2534 mm		
Custom Length	Add widths of units used		

! **CAUTION:** This fireplace is **NOT** load-bearing. Ensure the opening for the fireplace is framed in such a way that the weight of the building materials will not create pressure on the top of the fireplace.

! **NOTE:** The power cord is located at the top right back corner of the firebox. Plan the framing to allow routing the power cord to an outlet.

2. Lift the firebox into the opening in the frame using the handles on the back of the fireplace.

Figure 9

Left/Right Corner Installation

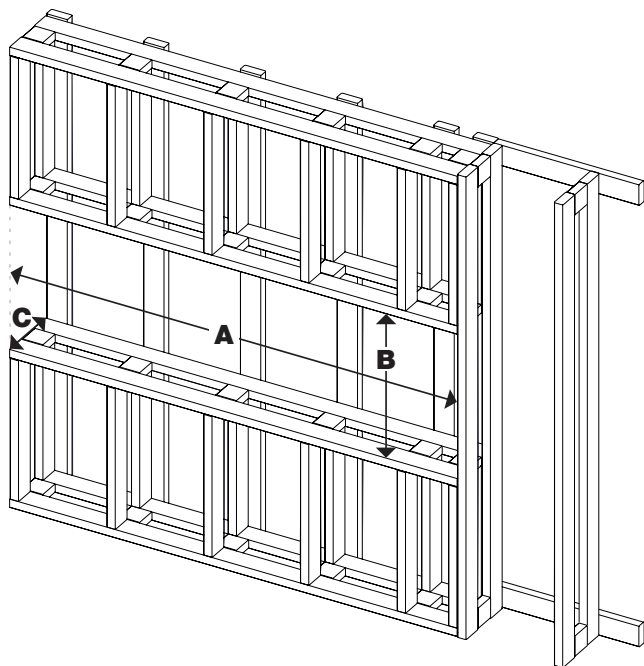

Figure 8

Bay Installation

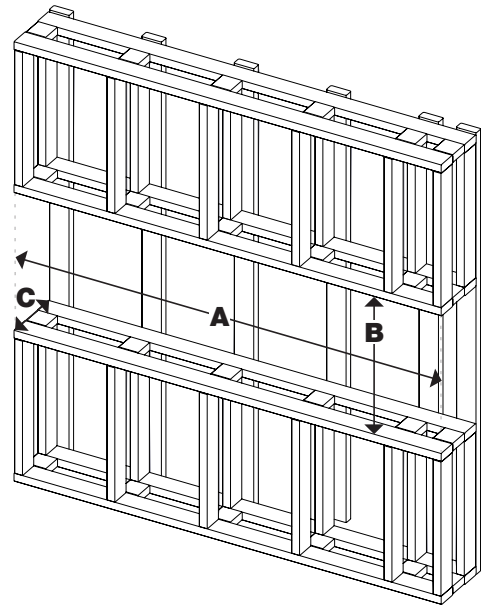
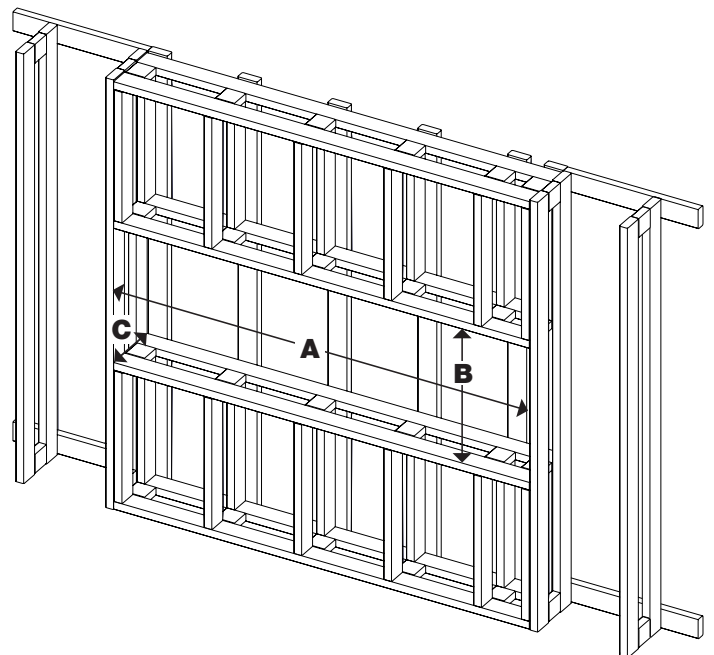

Figure 10

Front Installation



INSTALLATION

- ! **NOTE:** Ensure the instructions for *Preparing the Firebox for Installation* (p. 9) have been completed prior to installation.
- 3. Plug in the power cord coming from the fireplace.
- 4. Level the firebox. A bubble level is included in the hardware kit provided.
- 5. For multi-unit installations, install the joining brackets with the provided screws. (Figure 11) Use the provided clip to cover the bottom trim joint. (Figure 13)
- 6. Secure the mounting brackets to the framing on both the top and bottom using the provided wood screws. (Figure 14) The mounting brackets will prevent the firebox from shifting in the framing.
- 7. Install finishing material up to the trim. (Figures 15 and 16)
- ! **CAUTION:** Do not drill into firebox housing.
- 8. Finish the installation using the finishing materials of your choice.
- 9. Complete the installation using the instructions in the following sections: Mirrored Glass Installation (p. 15), Arranging Media (p. 15), Front Glass Installation (p. 17), and Side Glass Installation (p. 16).
- 10. (p. 15), Arranging Media (p. 15), Front Glass Installation (p. 17), and Side Glass Installation (p. 16).

Figure 11

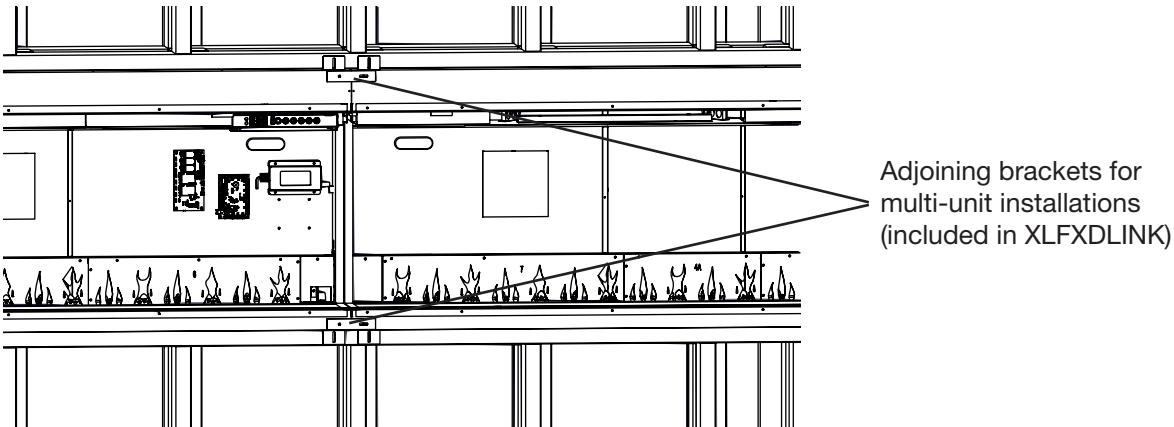
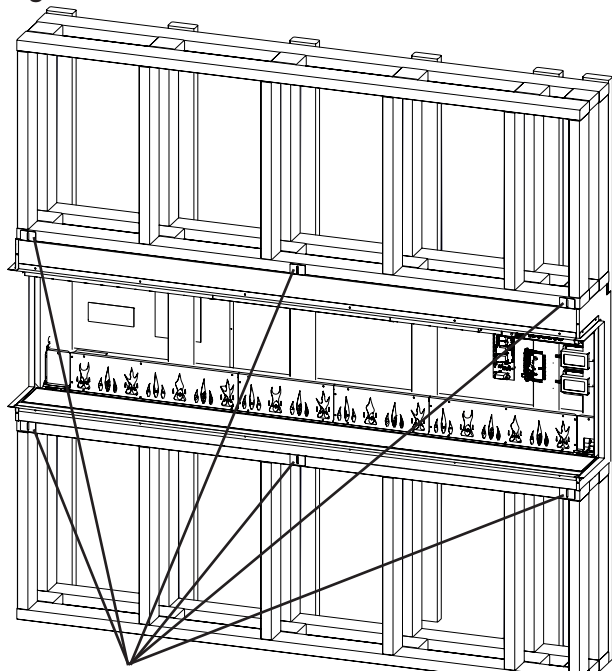
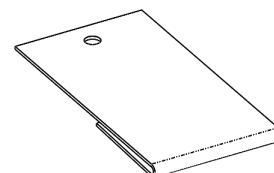

Figure 12



Mounting brackets
(center brackets not present on
BXL1200-AU units)

Figure 13



INSTALLATION

Figure 14

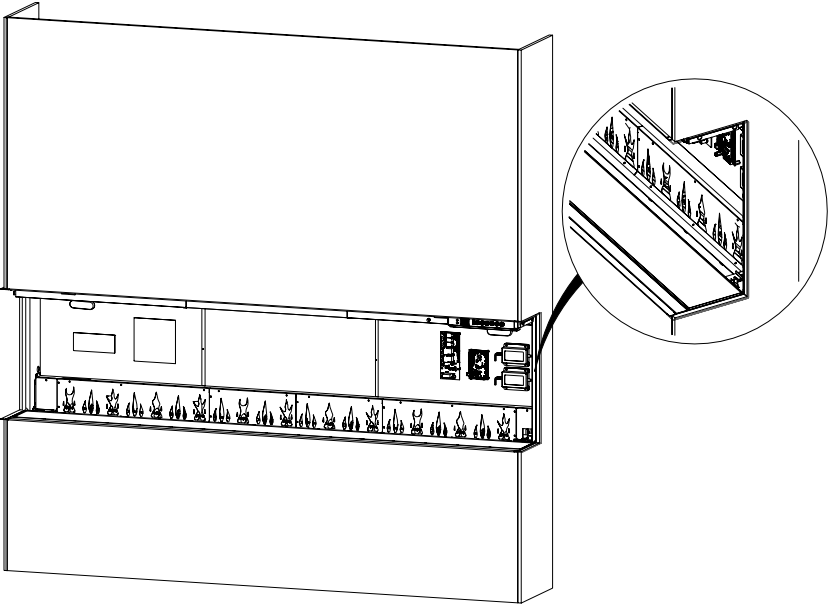
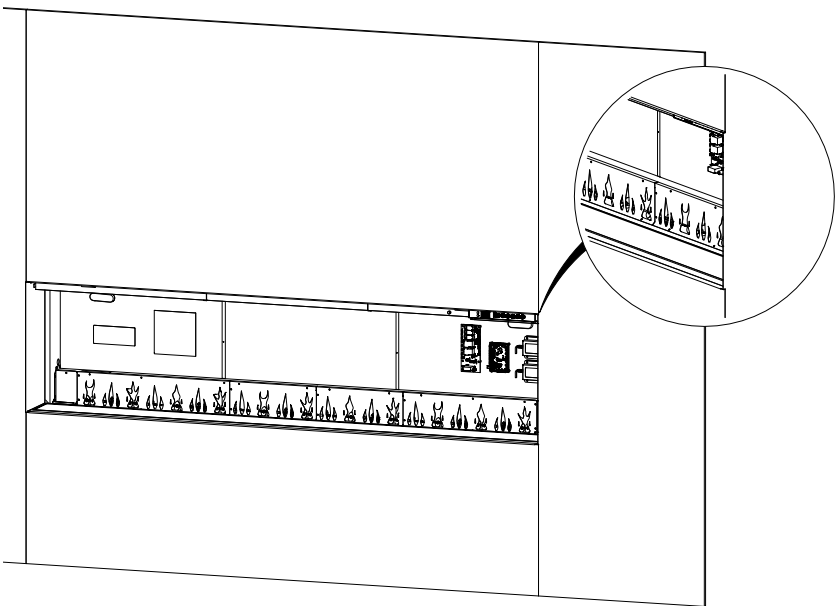

Figure 15



Heater Hardware Disconnect

The fireplace heater can be **permanently** disabled by removing the electronic jumper on the main control board.

! NOTE: Heater hardware disconnect will **permanently** disable the heater and fan. Follow these instructions only when an installation without heat is required. Temporary disabling of the heater can be achieved through the hidden touch controls. See “Heat Disable” in *Operation* section (p. 19) for instructions.

To disconnect the heater and fan permanently:

1. Locate the main control board. The heater hardware disconnect jumper location is labeled “Heater Disable”. (Figure 16)
2. Pull out the heater hardware disconnect jumper.

Figure 16

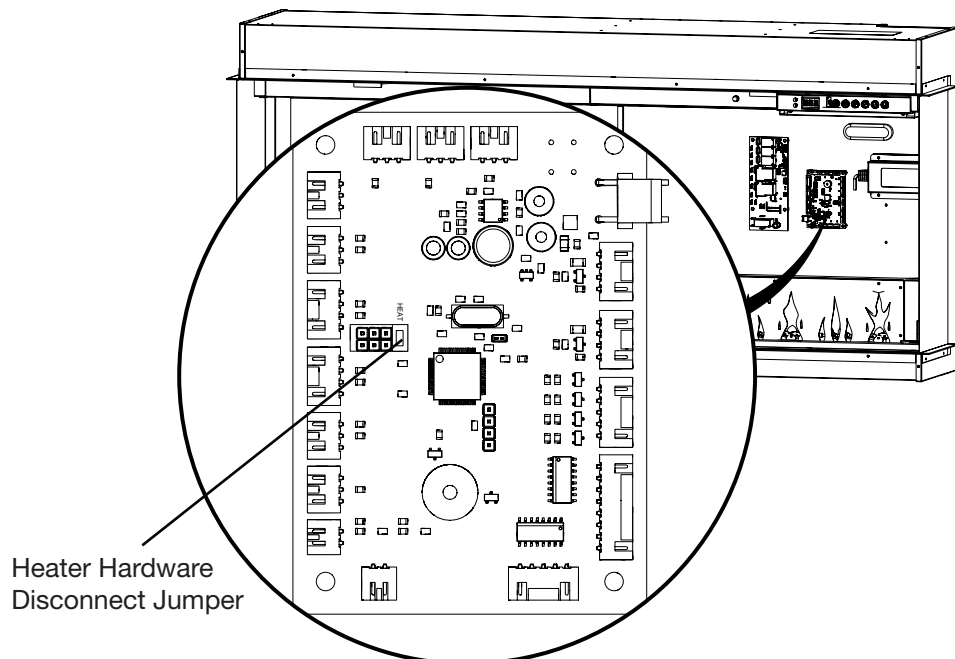

Mirrored Glass Installation

1. Attach the provided suction cup to the reflective side of the mirrored glass. Ensure the suction cup is securely attached.
 2. Using the suction cup to assist, lift the mirrored glass and place it into the bottom slot at an angle.
 3. Tilt the mirrored glass into a vertical position. (Figure 17)
 4. Align the holes on the inside of the unit with the holes on the bracket and install the mirrored glass brackets using the provided black screws. (Figure 18)
- ! NOTE:** Use a flashlight to locate the screw holes in the fireplace.
- ⚠ CAUTION:** Ensure the mirrored glass does not fall forward while the mirrored glass mounting brackets are being installed.
5. Remove the suction cup and clean any fingerprints or debris off the glass with a non-abrasive glass cleaner.
- ! NOTE:** Do not dispose of the suction cup! Keep it in a secure location, as it may be needed for maintenance and service on this fireplace.

Figure 17

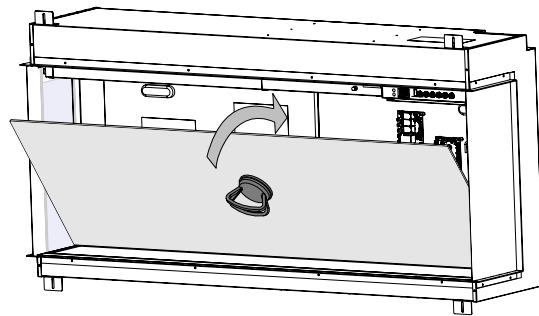
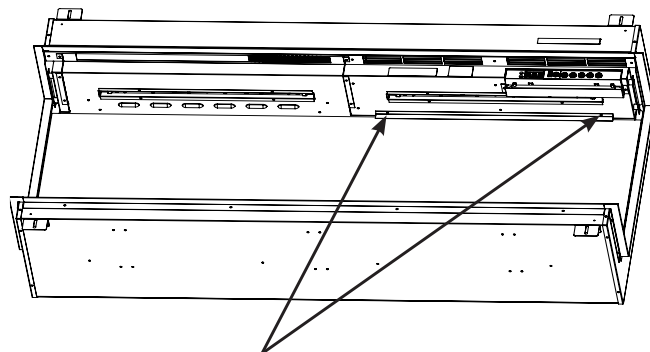

Figure 18



Mirrored Glass Bracket Screws

- ! NOTE:** BXLF1800-AU and BXLF2500-AU have two brackets. One bracket is on the inner top right side of the unit and the other is on the left.

Media Arrangement

For best results when using the supplied media, arrange as follows:

- ! NOTE:** Remove the plastic film from the media bed before adding the media.
1. Evenly disperse the river rock media to entirely cover the media bed.
 2. Place the driftwood pieces across the river rock media.
- ! NOTE:** To increase the media bed brightness, use fewer river rocks.

It is possible to use custom media ornaments to decorate your firebox. The custom media must fit easily without scratching the glass or bowing the media bed, and must not be composed of sand or liquid, which could interfere with the safety of the firebox.

Figure 19

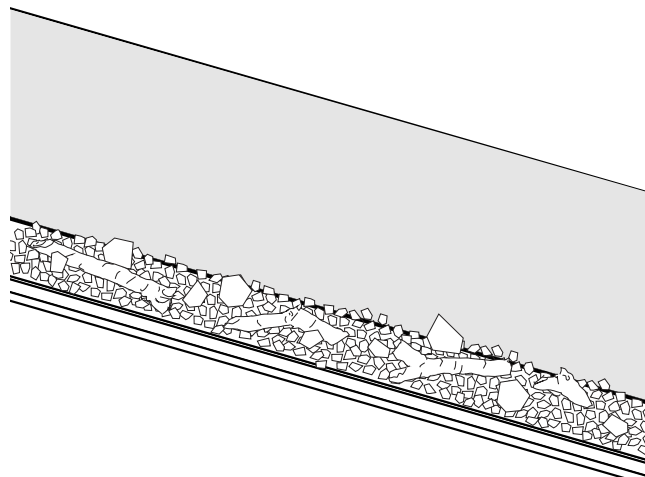

Side Glass Installation

1. Ensure the matte side of the upper black trimming is oriented toward the inside.
2. Insert the top of the glass panel into the upper slot.
3. Carefully tilt it toward the inside until it is in the vertical position. Once in place, it will drop into the correct position. (Figure 20)
4. Repeat on the other side for bay installations.

Figure 20

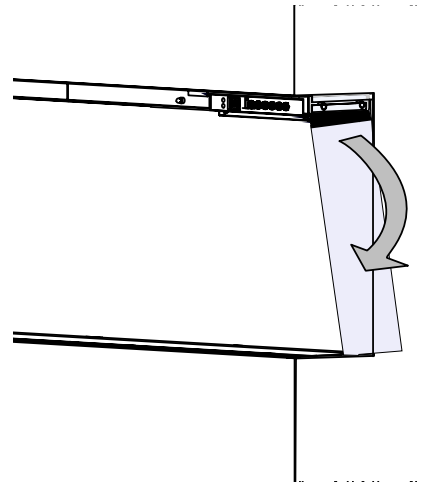

Front Glass Installation

! NOTE: Wait to power on the unit after the front glass is installed. If the power is already connected prior to the front glass installation, cycle the power on and off to engage the hidden touch controls.

1. Ensure there are no debris or finger prints on the mirrored glass, inner sides of the side glass, or on the inner side of the front glass before you begin.
2. Attach the provided suction cup to the outer side of the front glass. Ensure the suction cup is securely attached.
3. Using the suction cup to assist, lift the glass and place it into the bottom slot at an angle.
4. Tilt the glass into a vertical position. (Figure 21)
5. Secure using the provided front glass brackets and black screws provided. (Figure 22)

Figure 21

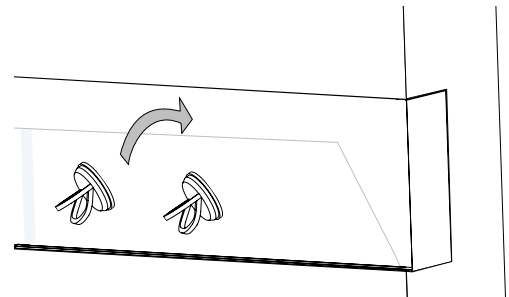
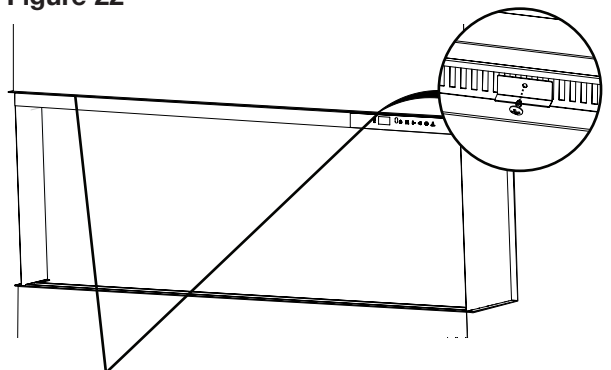

Figure 22



Front Glass Brackets

! NOTE: There is 1 front glass bracket for the BXLF1200-AU, and 2 front glass brackets for the BXLF1800-AU, and BXLF2500-AU units.

- ⚠ CAUTION:** Ensure the front glass does not fall forward while the glass mounting brackets are being installed.
6. Remove the suction cup and clean any fingerprints or debris off the glass with a nonabrasive glass cleaner.
- ! NOTE:** Do not dispose of the suction cup! Keep it in a secure location, as it may be needed for maintenance and service on this fireplace.

General Operation

⚠ WARNING: This electric firebox must be properly installed before it is used.

This firebox operates with ComfortSaver™ technology, which automatically adjusts the fan speed and heater wattage to safely and precisely match the requirements of the room based on the thermostat setting. The heater operates such that once the room reaches the set point, the fan and heater will continuously run at a low level, to maintain the desired room temperature. If the temperature in the room rises significantly, the heater will turn off and periodically turn back on to circulate the air around the unit, until the room temperature drops and requires the heater to be on again.

! NOTE: The element retains heat after shutdown. When the heat is turned off, there is a 2-minute cool down period before the fan shuts off completely.

! NOTE: The fireplace will retain the previously used settings after a power interruption.

Hidden Touch Controls

The hidden touch controls are located on the upper right of the fireplace. (Figure 23)

Remote Operation

The fireplace is supplied with a multifunction IR remote control. (Figure 24)

! NOTE: To operate correctly, the remote control must be pointed toward the front of the unit.

Resetting the Temperature Cutoff Switch

Should the heater overheat, a manual limit cut-out will turn the unit off and it will not come back on without being reset. If the **⏻** button on the unit is pressed, *Error* will be displayed on the unit. It can be reset by turning the unit off at the main disconnect panel and waiting 30 minutes before turning the unit back on.

⚠ CAUTION: If you need to continuously reset the heater, turn the unit off at the main disconnect panel and call technical support at: 1300 554 155 (AU) or +61 9 274 8265 (NZ).

Figure 23

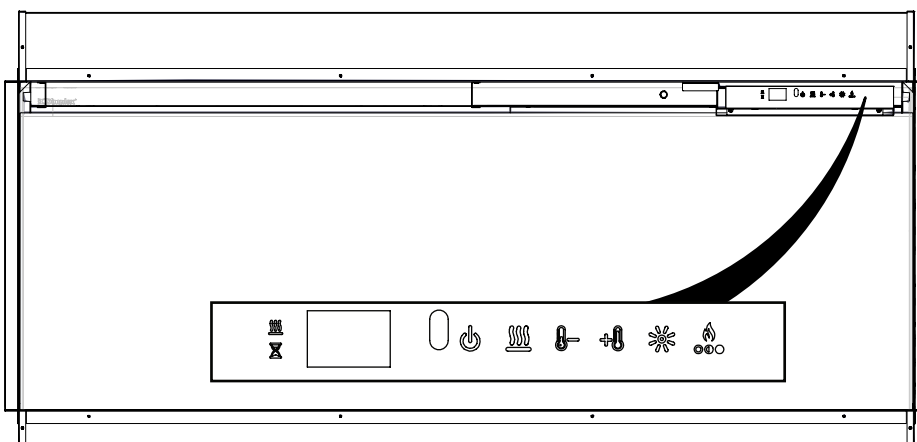
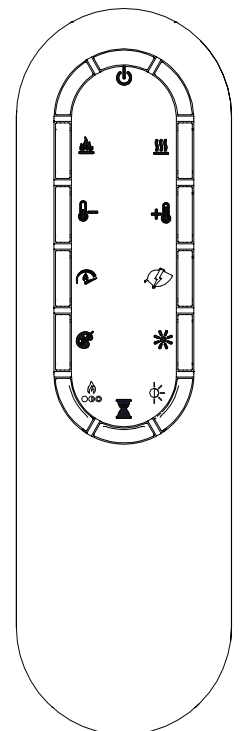









































Figure 24



OPERATION

	Standby	Press  to turn on the unit or to put it in standby mode. When the unit is turned back on, it will retain the previously used settings.
	Flame Effect	Press  to turn the flame effect, media, and overhead lights on or off.
	Heat	Press  to turn the heat on or off. The fireplace will beep once and the  icon will remain on the display when activated. The fireplace can be operated in heat only mode by turning off the flame and color effects.
	Heat Disable	Press and hold  and  at the same time for 3 seconds to disable or enable the heat function. This action must be performed on the hidden touch controls . When the heat is disabled and either the  ,  , or  is pressed, --- will appear on the display.
	Temperature Increase	Press  to increase the temperature setting.
	Temperature Decrease	Press  to decrease the temperature setting.
	Temperature Display (°C ↔ °F)	The temperature can be set from 7° C to 30° C (45° F to 86° F). When the temperature setting is adjusted, the set temperature will flash for 2 seconds, then the ambient room temperature will be displayed briefly.
	Temperature Display (°C ↔ °F)	Press and hold  and  at the same time for 3 seconds. This action must be performed on the hidden touch controls .
	Flame Speed	Press  repeatedly to cycle through the 5 different flame speeds.
	Heat Mode	Press  repeatedly to cycle through the 4 different heater modes: Normal: The element will automatically adjust itself to achieve and maintain the set temperature. Heat Boost: The element will work at maximum power for 20 minutes, then revert to normal heater mode. Eco: The element will work at reduced power to save energy. Fan: The element will turn off and only the fan will run.
	Moods	Press  repeatedly to cycle through the 8 different Moods, which are different combinations of overhead and media bed lighting. 1 - White 2 - Blue 3 - Violet 4 - Red 5 - Green 6 - Prism — media and overhead lights cycle through colors 7 - Kaleidoscope— media and overhead lights cycle through colors at different rates 8 - Midnight mode — media and overhead lights are off Press and hold  to turn the overhead lights on or off.
	Custom Color	Freeze the media and overhead lights to a custom color. When in Prism or Kaleidoscope modes (see Moods), press  while the desired color is displayed to freeze the cycle on that color. Press  again to resume the color cycle.

OPERATION

	Brightness	Press  repeatedly to cycle through the brightness and flicker modes. Solid <i>H</i> - High Brightness Solid <i>L</i> - Low Brightness Cycle <i>H</i> - High Brightness with flickering media and overhead lights Cycle <i>L</i> - Low Brightness with flickering media and overhead lights
	Flame Theme	Press  repeatedly to cycle through the 7 different flame themes: 1 - Base with orange and blue accents 2 - Base with orange accents 3 - Base with blue accents 4 - Blue 5 - Orange 6 - Base 7 - Orange and blue
	Ambient Light Sensor	Press  to turn the ambient light sensor on or off. The ambient light sensor will automatically adjust the brightness of the fireplace lights based on the ambient light in the room.
	Timer	Press  repeatedly until the desired number of hours of the timer is displayed. When this function is active, the fireplace will turn off after a set amount of time. The timer can be set from 30 minutes (display will show .5) to 8 hours in intervals of 30 minutes. To turn the timer off, press  repeatedly until  appears on the display. While the timer is active, press the timer button to see the time remaining.
	Factory Reset	Press and hold  and  at the same time for 3 seconds to reset all the settings to factory default. This action will also disconnect the unit from the Wi-Fi network if connected. This action must be performed on the hidden touch controls .

NEW! Flame Connect App



Download the **Flame Connect app** on your mobile device and create an account. With the app you can add an extra level of personalization, such as saving customized mood settings.

- Connect your electric fireplaces
- Add as many fireplaces as you like to the Flame Connect App.
- Personalize your product
- Change modes and settings on your fireplace to suit your mood.
- Secure your device
- Take ownership of a product to prevent unauthorized access.

For additional information, visit dimplex.com/fcapp



Remote Control Battery Replacement

To replace the battery:

1. Remove battery cover of the remote control using a Philips screwdriver.
2. Correctly install one 3 Volt (CR2032 [longer life] or CR2025) battery in the battery holder with the + side facing up.
3. Secure the battery cover using the previously removed screw.



Battery must be recycled or disposed of properly. Check with your Local Authority or Retailer for recycling advice in your area.

Figure 25

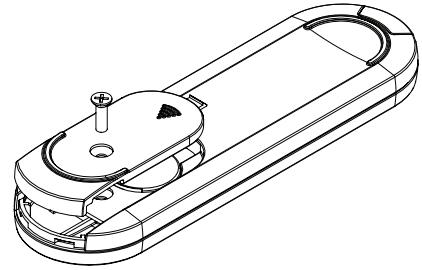

⚠WARNING: Disconnect power and allow heater to cool before attempting any maintenance or cleaning to reduce the risk of fire, electric shock or damage to persons.

Partially Reflective Glass Cleaning

The partially reflective glass is cleaned in the factory during the assembly operation. During shipment, installation, handling, etc., the partially reflective glass may collect dust particles; these can be removed by dusting lightly with a clean dry cloth.

To remove fingerprints or other marks, the partially reflective glass can be cleaned with a damp cloth. The partially reflective glass should be completely dried with a lint-free cloth to prevent water spots. To prevent scratching, do not use abrasive cleaners.

Fireplace Surface Cleaning

Use only a damp cloth to clean painted surfaces of the fireplace. Do not use abrasive cleaners.



The fireplace should not be operated with an accumulation of dust or dirt on or in the unit, as this can cause a build-up of heat and eventual damage. For this reason the heater must be inspected regularly, depending upon conditions and at a minimum yearly intervals.

Servicing

Except for installation and cleaning described in this manual, an authorized service representative should perform any other servicing.

TROUBLESHOOTING

For more troubleshooting, consult the BXLF Service Manual which can be found at www.realflame.com.au or www.realflame.co.nz

Problem	Display	Cause	Solution
Fireplace does not turn on with the manual touch controls	N/A	No incoming power	Ensure unit is receiving power Check main disconnect panel Ensure wall switch is on (if applicable)
Fireplace does not turn on with the remote control	N/A	The batteries in the remote control are dead or installed incorrectly	Replace remote control battery Ensure battery is installed with + facing up.
Heater does not turn on	---	Heater is disabled	Press and hold  and  at the same time on the hidden touch controls for 3 seconds to disable or enable the heat function.
	H--	Heater has been permanently disabled	If installation with heat is desired, reinstall jumper on main board if available or purchase new main board.
Heater is on, but there is no heat		Normal operation — There is a 30-second delay before heater starts	No action required.
Circuit breaker trips or fuse blows when unit is turned on	N/A	Improper circuit current rating	Plug unit into a dedicated minimum 10 amp circuit.
Error Code is displayed	Err 1	Temperature cut-out is activated	Unplug power cord and wait 5 minutes before turning the unit back on. If error persists, see Service Manual.
	Err 12	Ambient temperature is above 45° C (113° F)	No action required.
	Err 13	Ambient temperature is below 5° C (41° F)	No action required.
	Err 1b	NTC not detected	See service manual.
	Err 23	Relay board not detected	See service manual.

WIRING DIAGRAMS

BXLF1200-AU

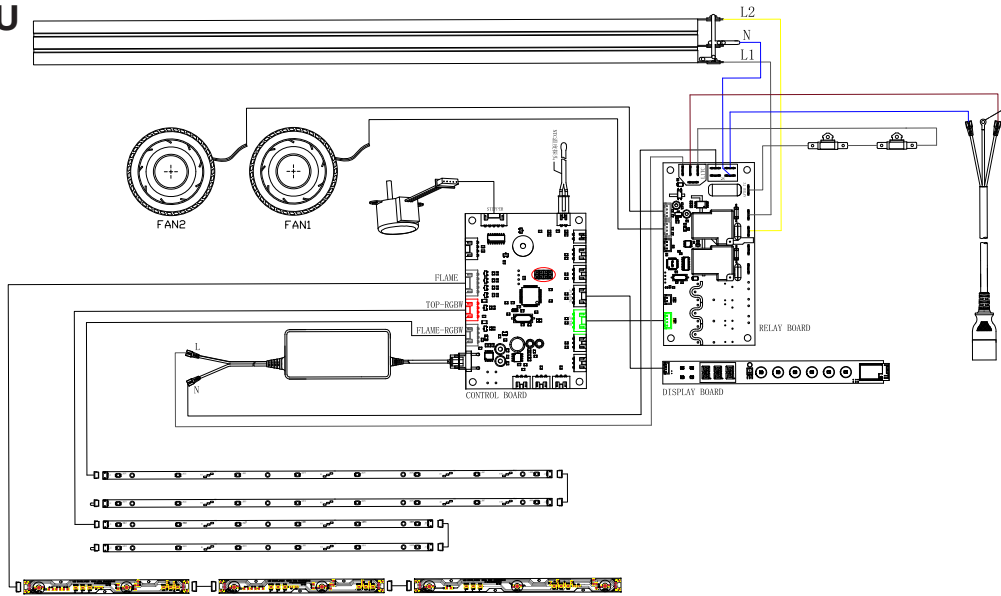

BXLF1800-AU

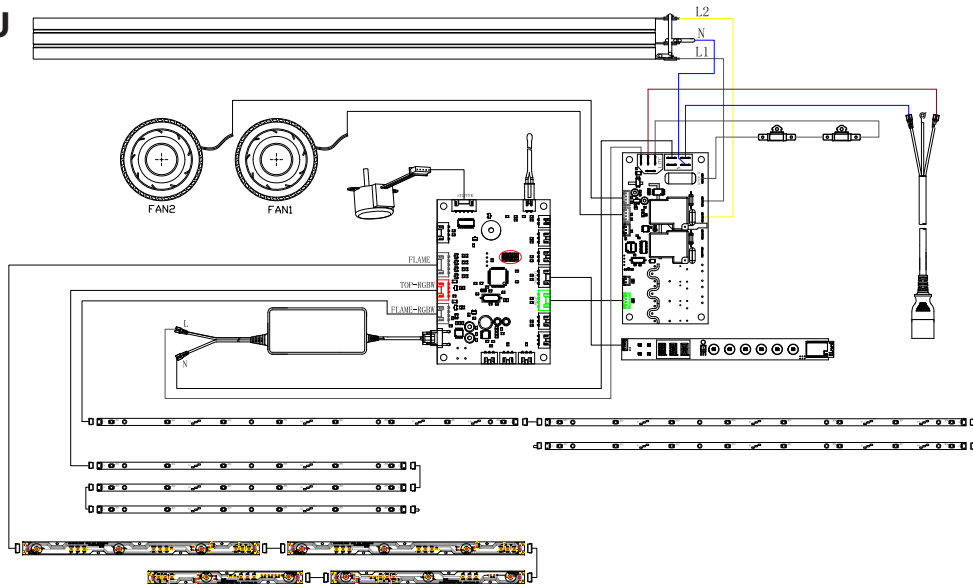

BXLF2500-AU

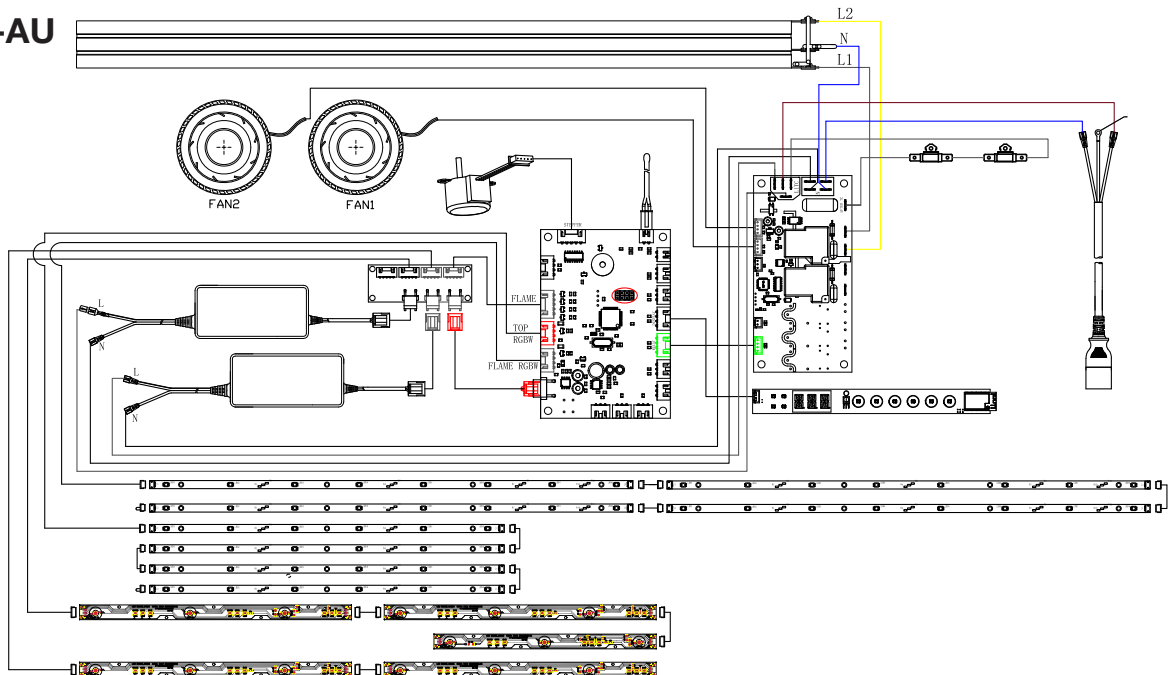

WARRANTY

IGNITEXL BOLD 2-YEAR LIMITED WARRANTY

Products to which this limited warranty applies

This limited warranty applies to your newly purchased Real Flame IGNITE XL BOLD fireplace. This limited warranty applies only to purchases made in any State and Territory of Australia and New Zealand. This limited warranty applies to the original purchaser of the product only and is not transferable.

What this limited warranty covers and for how long

Products covered by this limited warranty have been tested and inspected prior to shipment and, subject to the provisions of this warranty, Glen Dimplex warrants such products to be free from defects in material and workmanship for a period of 2 years from the date of the first purchase of this product. The limited 2 year warranty period also applies to any implied warranties that may exist under applicable law. Some jurisdictions do not allow limitations on how long an implied warranty lasts, so the above limitation may not apply to the purchaser.

What this limited warranty does not cover

This limited warranty does not apply to products that have been repaired (except by Glen Dimplex or its authorised service representatives) or otherwise altered. This limited warranty does further not apply to defects resulting from misuse, abuse, accident, neglect, incorrect installation, improper maintenance or handling, or operation with an incorrect power source.

What you must do to get service under this limited warranty

Defects must be brought to the attention of Technical Service at 1300 554 155 for Australia and 09 274 8265 for New Zealand. Please have proof of purchase, catalogue/model and serial numbers available when calling. Limited warranty service requires a proof of purchase of the product.

What Glen Dimplex will do in the event of a defect

In the event a product or part covered by this limited warranty is proven to be defective in material or workmanship during the 2 years limited warranty period you have the following rights:

1) Glen Dimplex will in its sole discretion either repair or replace such defective product or part without charge. If Glen Dimplex is unable to repair or replace such product

or part, or if repair or replacement is not commercially practicable or cannot be timely made, Glen Dimplex may, in lieu of repair or replacement, choose to refund the purchase price for such product or part.

2) Limited warranty service will be performed solely by dealers or service agents of Glen Dimplex authorised to provide limited warranty services.

3) The purchaser is responsible for removal and transportation of such product or part (and any repaired or replacement product or part) to and from the authorised dealer's or service agent's place of business.

4) This limited warranty does not entitle the purchaser to on-site or in-home services. On-site or in-home services may be performed at the purchaser's request and expense at Glen Dimplex's then-current rates for such services.

5) Glen Dimplex will not be responsible for, and the limited warranty services shall not include, any

expense incurred for installation or removal of the product or part (or any replacement product or part) or any labour or transportation costs. Such costs shall be the purchaser's responsibility.

What Glen Dimplex and its dealers and service agents are also not responsible for:

IN NO EVENT WILL GLEN DIMPLEX, OR ITS DIRECTORS, OFFICERS, OR AGENTS, BE LIABLE TO THE PURCHASER OR ANY THIRD PARTY, WHETHER IN CONTRACT, IN TORT, OR ON ANY OTHER BASIS, FOR ANY INDIRECT, SPECIAL, PUNITIVE, EXEMPLARY, CONSEQUENTIAL, OR INCIDENTAL LOSS, COST, OR DAMAGE ARISING OUT OF OR IN CONNECTION WITH THE SALE, MAINTENANCE, USE, OR INABILITY TO USE THE PRODUCT, EVEN IF GLEN DIMPLEX OR ITS DIRECTORS, OFFICERS, OR AGENTS HAVE BEEN ADVISED OF THE POSSIBILITY OF SUCH LOSSES, COSTS OR DAMAGES, OR IF SUCH LOSSES, COSTS, OR DAMAGES ARE FORESEEABLE. IN NO EVENT WILL GLEN DIMPLEX, OR ITS OFFICERS, DIRECTORS, OR AGENTS BE LIABLE FOR ANY DIRECT LOSSES, COSTS, OR DAMAGES THAT EXCEED THE PURCHASE PRICE OF THE PRODUCT. SOME JURISDICTIONS DO NOT ALLOW THE EXCLUSION OR LIMITATION OF INCIDENTAL OR CONSEQUENTIAL DAMAGES, SO THE ABOVE LIMITATION OR EXCLUSION MAY NOT APPLY TO THE PURCHASER.

RECYCLING



At the end of the electrical products useful life it should not be disposed of with household waste. Please recycle where facilities exist. Check with your Local Authority or retailer for recycling advice in your area.



Website:

Telephone:

www.realflame.com.au

AU: 1300 554 155

www.realflame.co.nz

NZ: +64 9 274 8265

This product is protected by Intellectual property rights and patents owned by the Glen Dimplex Group on an international basis. The Glen Dimplex Group of Companies will actively protect these rights.

© Glen Dimplex.

All rights reserved. Material contained in this publication may not be reproduced in whole or in part, without prior permission in writing from Glen Dimplex.