

DFS940 Freestanding Gas Fireplace

Information Sheet for Builders and Architects

FIRE BY **escea.**

SPECIFICATIONS

Heat Output	6.9 kw
Gas Input	29 MJ/hr (NG), 31 MJ/hr (ULPG/Propane)
Gas Connection	Lower rear of fireplace - 1/2" BSPT Female
Gas Type	Natural Gas or Propane or ULPG
Power Requirement	3 pin, 230V AC mains power within 1m
Operation	Thermostatic RF remote control
Appliance Weight	80kg (DF960) + 99kg (DFS940 Console)
Connections	Lower right rear of fireplace
Clearance to Combustibles	Zero clearance from fireplace surfaces
Service Access Hatch	Not Required
Certification	Complies with AS/NZS 5263.1.3
Installation Compliance	AS/NZS5601.1 and DF Series Install Manual



Flue System	Power direct-vent with 100/75mm Ø flexible and rigid PP flue pipes†
Flue Termination Locations	Roof or wall mounted terminations
Minimum Flue Length	400mm
Max. Flexible Flue Length	4m†
Max. Insulated Flexible Flue Length	N/A
Maximum Flue Length	12m†
Flue Bends Allowed	Max. 10 bends in any flue run

INSTALLATION

1

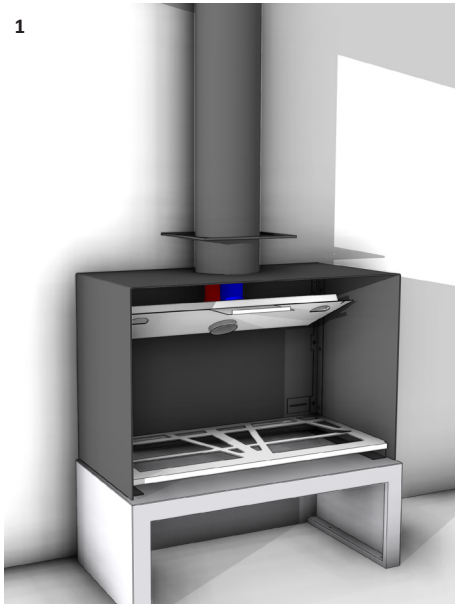

Locate the freestanding console in the desired location, complying with all clearances. Allow for an electrical outlet within 1m. Remove the console fascia and set aside. Install the black rigid liners to the console, run the twin flexible flue pipes and connect to the removable flue spigot plate. Connect the powerflue electrical cable at both ends.

2



Secure the freestanding console to the floor, base or plinth. Install the DFS960 fireplace into the freestanding console connecting the flue spigot plate to the fireplace. Connect gas supply and powerflue electrical cable. Connect power supply to wall outlet. Complete commissioning of the fireplace and flue.

3



Fit the fascia components back to the console. Install the ceiling plate to cover the hole for the flue pipes. Complete the project with any remaining fixtures and finishes.

† Refer to the *Escea DFS Flue Specification Guide*

DFS940 Freestanding Gas Fireplace

Information Sheet for Builders and Architects

FIRE BY **escea.**

FREESTANDING CONSOLE DIMENSIONS

Freestanding Console Width (A)	994mm
Freestanding Console Height (B)	663mm
Freestanding Console Depth (C)	528mm
DF960 Fireplace Width	940mm
DF960 Fireplace Height	598mm
DF960 Fireplace Depth	400mm
Glass Viewing Area Width	872mm
Glass Viewing Area Height	464mm

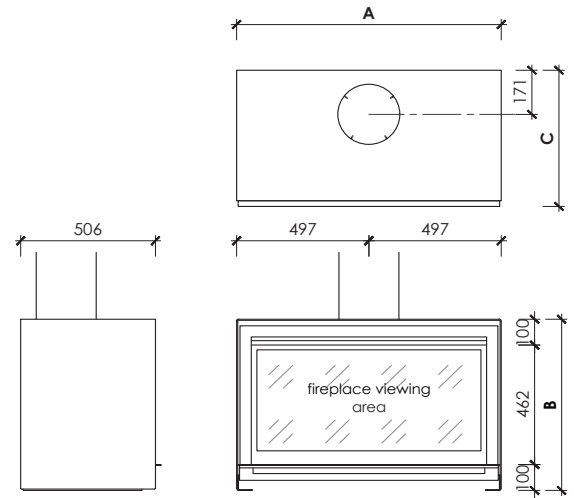

FIREPLACE BASE

Install the DFS940 freestanding console on a firm, continuous surface such as concrete, or a framed structure overlaid with solid finishing surface. This can be a combustible or non-combustible material. Escea can provide a GRC plinth that is designed to compliment the fireplace.

CONNECTIONS

Gas and electrical supply connections can all be made from behind the freestanding console and through the back panel, or through the base of the freestanding console. Refer to the *DFS Series Installation Manual* for exact locations. Smart Heat connection is via Wi-Fi.

HEARTH

When the DFS940 freestanding console is at floor level, a hearth is not required, however it may be used for decorative purposes. Do not obstruct the fireplace.

FLUE OPTIONS

Three flue options are available for the DFS940 Freestanding Fireplace.

DFS Horizontal Powerflue Kit: For freestanding fireplace flue terminations on an external wall, twin flue pipes extend from the fireplace to a wall-mounted flue terminal. These pipes are enclosed in 225mm Ø black flue liners, incorporating a 90° elbow. The total flexible flue length is 4m, allowing both vertical and horizontal flue pathways.

DFS External Vertical Powerflue Kit: Designed for situations without an accessible roof space, but optimal for flue fan servicing from the roof. 225mm Ø black flue liners contain the twin flexible flue pipes, for the initial 2.4m from the fireplace. The total flexible flue length is 6m, allowing both vertical and horizontal flue pathways. In most scenarios, installing the Freestanding External Vertical powerflue will be simpler and faster.

DFS Internal Vertical Powerflue Kit: Ideal for freestanding installations where the flue fan must be in the roof space. 225mm Ø black flue liners contain the twin flexible flue pipes, for the initial 2.4m from the fireplace. No flue liners are needed in the roof space. The total flexible flue length is 4m, allowing both vertical and horizontal flue pathways.

FIREPLACE CLEARANCES TO COMBUSTIBLE MATERIALS

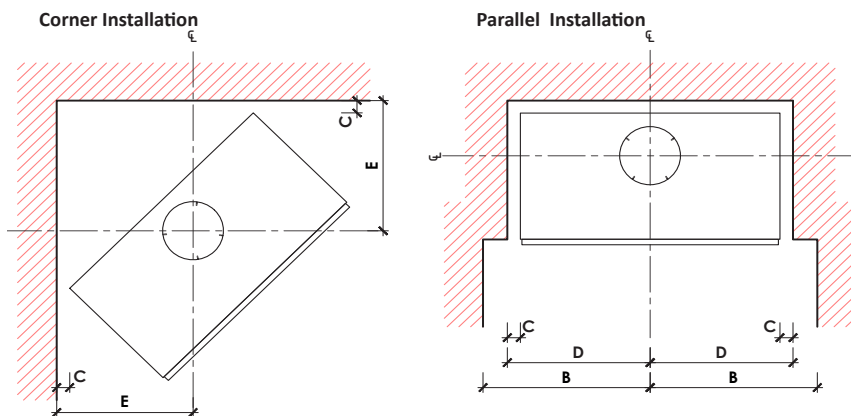

Clearance Guidelines: Adhere to combustible building material clearances in all directions around the fireplace: front clearance **1000mm**. Ensure soft furnishings do not come into contact with any part of the freestanding console.

Rear Clearance (A): Maintain a clearance of **221mm** from the flue liner centre to a wall behind the fireplace.

Side Wall (B): Maintain a distance of **640mm** from the flue centre where a side wall extends forward of the fireplace.

Side Clearance (C): Maintain a distance of **50mm** from the side of the freestanding console to an adjacent side wall. Dimension **D (547mm)** indicates the same clearance to a side wall, but from the flue centreline.

Corner Installations (E): When in a corner installation, maintain a clearance of **522mm** from the flue liner centre to a wall behind the fireplace.

Install in accordance with AS/NZS 5601 and the *Escea DFS Series Install Manual*.
For installation methods not covered in this document please contact:
Email: aa@escea.com PH (NZ): 0800 17 3000 PH (AU): 1800 460 832

Install Manual and CAD files are available via the QR Code or link:
www.escea.com/technical



Disclaimer:

Dimensions provided are indicative and may not consider all site-specific variations or installation needs. Verify dimensions on-site before manufacturing or construction.