

Jade MK2 Freestanding

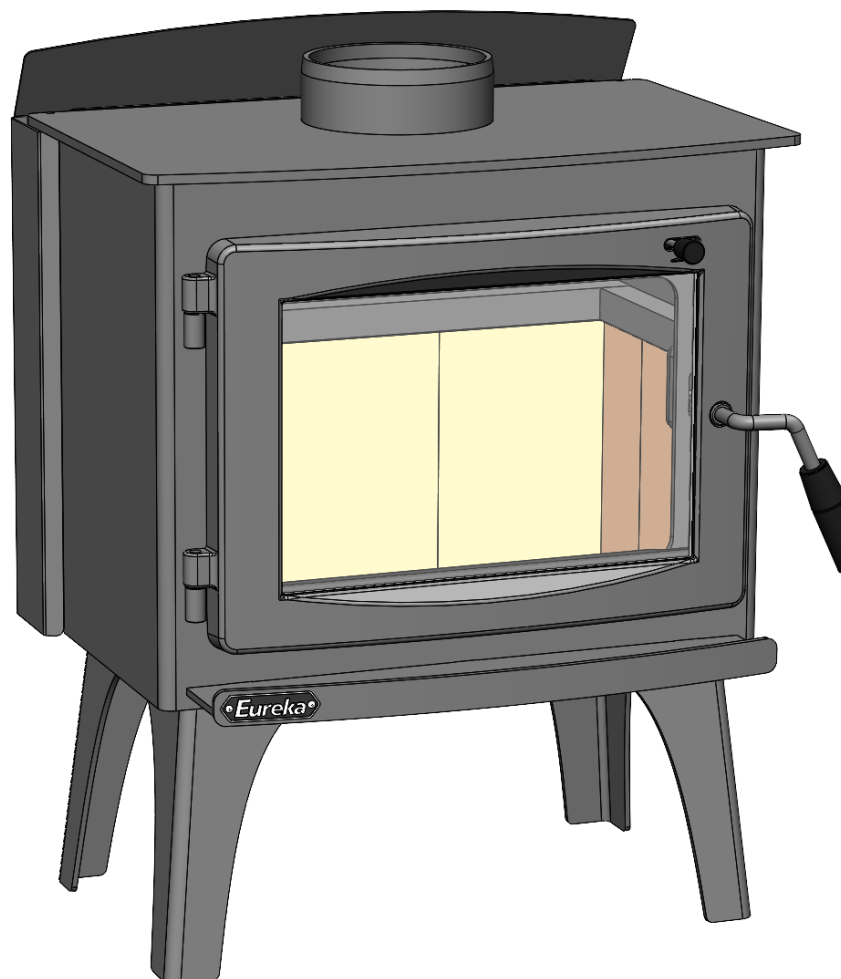

Please keep these instructions for future reference.

Dont forget to register your warranty using the QR code on the door glass or
head to www.eurekaheating.com.au/warranty

OPERATION & INSTALLATION MANUAL

WARNING



Congratulations on the purchase of your new wood heating appliance. Read and follow these instructions carefully before installing and using this appliance.



SAFE OPERATION

- A flue fire with resulting damage may occur if the appliance is not installed and maintained as per this booklet.
- Never place combustible materials such as wood, paper or furniture near the appliance.
- This appliance is designed to burn dry hardwood. Do not burn rubbish, driftwood, flammable liquids, pressurised canisters, or any substance containing salt or corrosives.
- This appliance must not be installed and operated in an area where kerosene, petrol, paint thinners, or other flammable liquid is used or stored.
- The flue system must be inspected and cleaned annually or sooner if required. Failure to do so could result in excessive build up of creosote which may result in a flue fire, which may damage the flue or cause damage to your home.
- The surface of the appliance becomes hot during operation. Do not touch the surface of this appliance. Keep children away from the appliance during operation. Do not allow anyone to operate this appliance who is not familiar with this instruction booklet.



PAINT CURING & CARE

Your heater is coated with the best available heat resistant paint. Even though the paint has been baked after application, it will require further temperature curing. It may discolour if you overfire the the heater on its first fire. Please follow these instructions carefully to ensure the quality of the paint on your heater is maintained.

- For the first two or three firings, never exceed medium air setting and do not load the fire more than half full. Do not use softwood fuel (cut up pallets etc.) other than for kindling when first lighting the fire.
- On the initial fire up you may detect smoke coming from the paint finish, and from any oils that may be impregnated in the steel of the firebox. This is normal. It is suggested to well ventilate your home on the initial fire up.
- Do not wipe the heater while the paint is curing. After the paint has cured, the only maintenance required to maintain the heater's finish is to wipe it with a soft cloth (with water if necessary). **DO NOT USE ANY COMMERCIAL CLEANERS OR SOLVENTS ON THE PAINT FINISH.**
- We are proud of the presentation of our products. If at any time you need to freshen up the paint, your local Eureka dealer has touch-up paint available for purchase. The heater is painted in Stove Bright Metallic Black - Paint code 6309.

If you have any enquiries, please contact the dealer from whom you purchased your heater:

PLEASE COMPLETE:

Dealer Name: _____

Dealer Address: _____

Phone: _____

Please attach your original purchase dockets to this booklet for future reference.

Installation



WARNING

INSTALLATION

THE INSTALLATION OF THIS APPLIANCE MUST BE CARRIED OUT AS PER THIS MANUAL AND THE FLUE MANUFACTURER'S SPECIFICATIONS.

WE RECOMMEND THAT YOU USE A QUALIFIED INSTALLER TO CARRY OUT THE INSTALLATION OF THIS APPLIANCE.

EXTREME CARE SHOULD BE TAKEN WHEN HANDLING THE APPLIANCE.

IF YOU HAVE ANY OTHER ENQUIRIES REGARDING INSTALLATION OF THE APPLIANCE, PLEASE CONTACT THE DEALER FROM WHOM YOU PURCHASED THE HEATER.

Scope Of Installation Specifications:

Your new wood heater was tested in accordance with AS/NZS 2918:2018 for the configurations and flue types specified in this manual. Any installation that falls outside of the specifications in this manual other than the addition of bends or extensions to the flue, is considered to be an untested installation as per AS/NZS 2918:2018. AF Gason Pty. Ltd. accepts no liability whatsoever for the safety of installations under such circumstances.

AF Gason Pty. Ltd. accepts no liability whatsoever for any interpretation of AS/NZS 2918:2018.

It is important that you understand these installation instructions and minimum clearances to combustible materials before selecting a position for your wood heater, to ensure a safe and correct installation is achieved.

Installation Permit:

Depending on your local authority requirements, a permit may be required for the installation of your heater. It is your responsibility to arrange the same.

Flue Requirements:

As per the dimensions in Table A (referencing figures 1 and 2), the Eureka Jade must be installed with either of the following flue types:

- Standard 6" Decromesh Default Flue Kit incorporating an additional 900mm high x 180 degree stainless steel rear flue shield fitted between the Decromesh and the active flue, or
- 6" Half shield Default Kit (Double Sleeve Flue Kit).

NOTE THAT INSTALLATION CLEARANCES ARE DIFFERENT FOR EACH FLUE TYPE.

The flue system installed must comply with Australian and New Zealand installation standards AS/NZS 2918:2018, and be installed to the flue manufacturer's instructions.

The performance of your heater is highly dependant on an effective flue system. In many cases, poor start-up, dirty glass, down draft causing smoke spillage when the door is open, and reduced heat output, can all be caused by the flue system being too short or incorrectly installed. Excessive flue length is also undesirable, as it can cause excessive flue draft, resulting in short burn times and over-firing of the heater.

Clearance To Combustibles:

The Eureka Jade conforms to AS/NZS 2918:2018 when positioned in relation to combustible surfaces as specified in Table A (referencing figures 1 and 2), and as per these instructions. The figures shown state the minimum distance the heater can be placed in relation to any combustible materials - plaster, wallpaper, timber, MDF, etc.

In the instance that your Eureka heater is surrounded by non-combustible materials - brick, stone, concrete, cement sheet or similar, wall clearances can be reduced to 50mm. A 50mm clearance is required to ensure room air can circulate around the wood heater during operation. For further information regarding installation of your heater, please contact the Eureka dealer from whom you purchased the heater.

Installation

Hearth & Floor Requirements:

If the appliance is to be installed onto a combustible floor, a cement sheet or similar non-combustible hearth or floor protector that has a thermal resistivity of 0.026m² must be placed in between the appliance and the combustible floor. Minimum hearth requirements are specified below. If the heater is to be installed onto a non-combustible surface that meets the minimum floor protector requirements specified, an additional floor protector may not be required.

Clearances Information

Table A

Dim.	6" Decromesh Default Flue kit with half shield	6" Half Shield default flue kit (Double sleeve flue kit)
A	6	6
B	780	780
C	350 (300 from front of door)	350 (300 from front of door)
D	885	860
E	575	600
F	175	150
G	375	375
H	806	806
I	1358	1358

Figure 1 - Parallel Installation

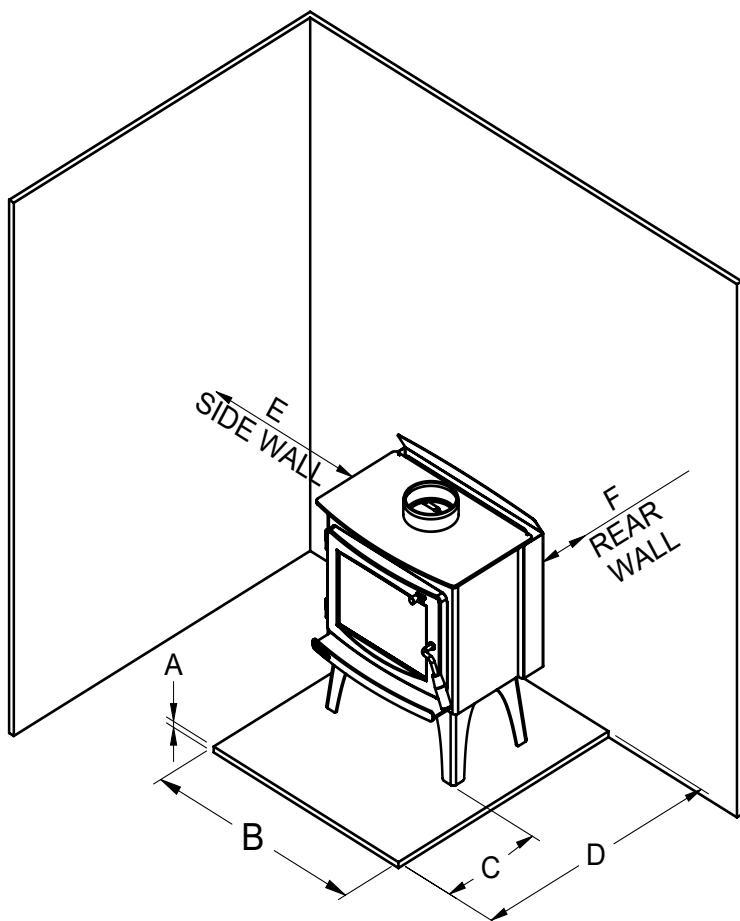
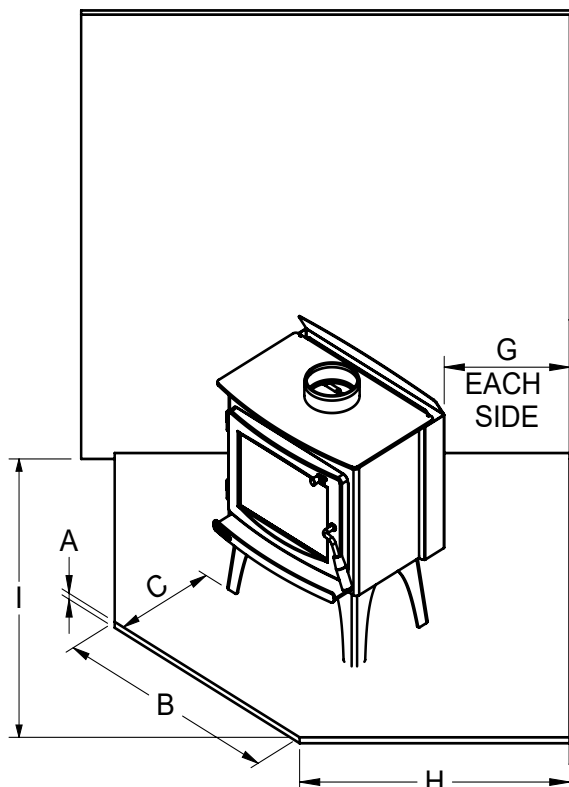

Figure 2 - Corner Installation



Installation

Removing heater from pallet

- Remove the carton, foam and plastic bag from your new heater
- Remove the transport brackets securing your heater to the pallet
- To aid heater installation, remove door, baffle plate, brick set, brick retainer and ash deflector from heater to reduce overall weight
- Remove heater from pallet using lifting aid.

Overall Heater Weight and Dimensions

O/All weight: 125kg

Heater Weight : 118kg

Appliance Dimensions: **585W** x **455D** x **770H**

Carton Dimensions (overall) **680W** x **515D** x **845H**

Installing Baffle Plates

Your Eureka Jade utilizes a dual baffle plate system with a 6mm upper baffle and a 6mm dual skinned lower baffle with incorporated secondary air. When removing the baffle plates to clean the flue, the baffle plates must be inspected and replaced in the configuration as shown in Figure 3. If either baffle plate develops holes, cracks or significant warping it is important that it is replaced to maintain performance and ensure longevity of the firebox.

Figure 3

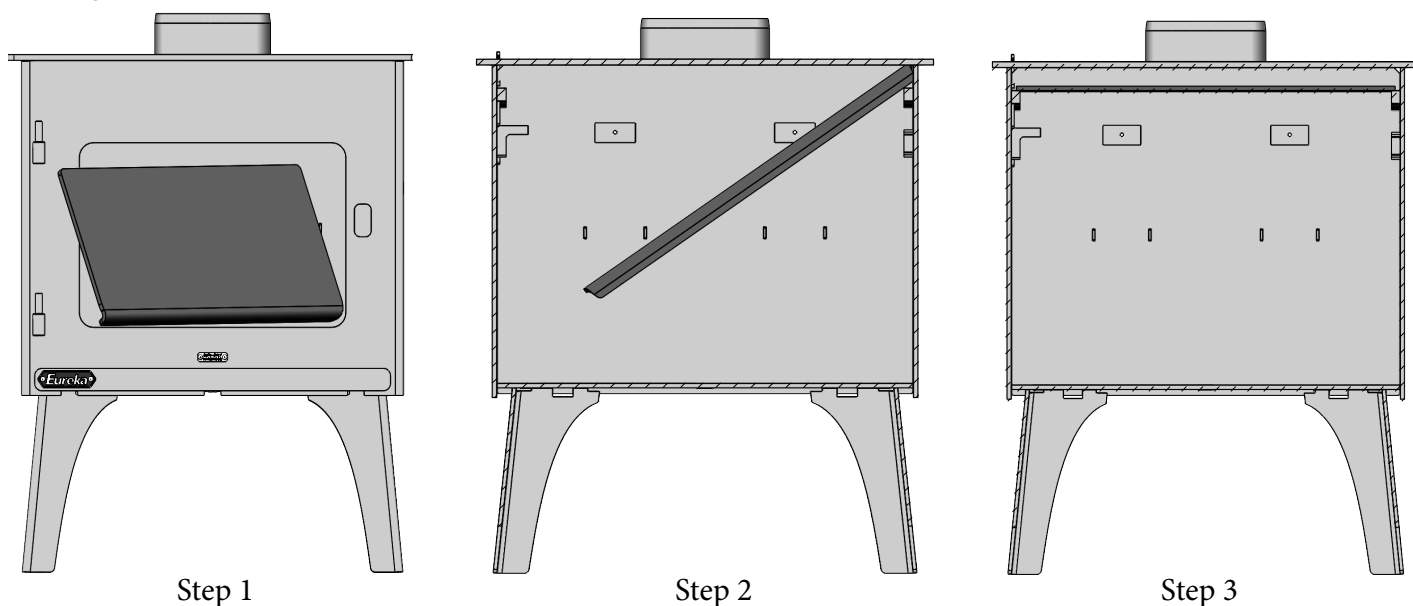

Upper Baffle Installation

Step 1: Orientate the baffle plate with folded lip facing down and at the front.

Feed the baffle through the door opening and rotate it so it's flat with the folded edge facing down and towards the front of the heater.

Step 2: Lift the right side of the baffle up so that the baffle is angled up and slide it into the corner of the firebox on top of the upper baffle hanger.

Step 3: Ensuring the baffle plate is all the way forward lift the other side of the baffle up above the upper hanger and slide it across so it sits evenly on both upper hangers. Re-check that it's sitting flat and is all the way forward. The upper baffle plate is now installed.

Installation

Lower Baffle Installation

1. Position the baffle in the door opening as per (1) with the baffle lip facing the floor and the air intake tubes facing the ceiling.
2. Feed the baffle through the door opening, towards the right rear corner of the firebox.
3. Once the baffle is through the door opening, rotate it so the baffle is square with the firebox, with the front lip curling upwards, and the flat side facing down (2).
4. With the rear of the baffle plate pressed against the bottom back corner of the firebox, lift the baffle plate tilting the front lip up, and over the "Front baffle support" (3).
5. Slide the baffle plate forward over the "Front baffle support", then raise the rear and slide the channels of the baffle into the "Rear baffle slots". Ensure baffle is pressed hard against rear of firebox. The lower baffle plate is now installed correctly (4).

Figure 4

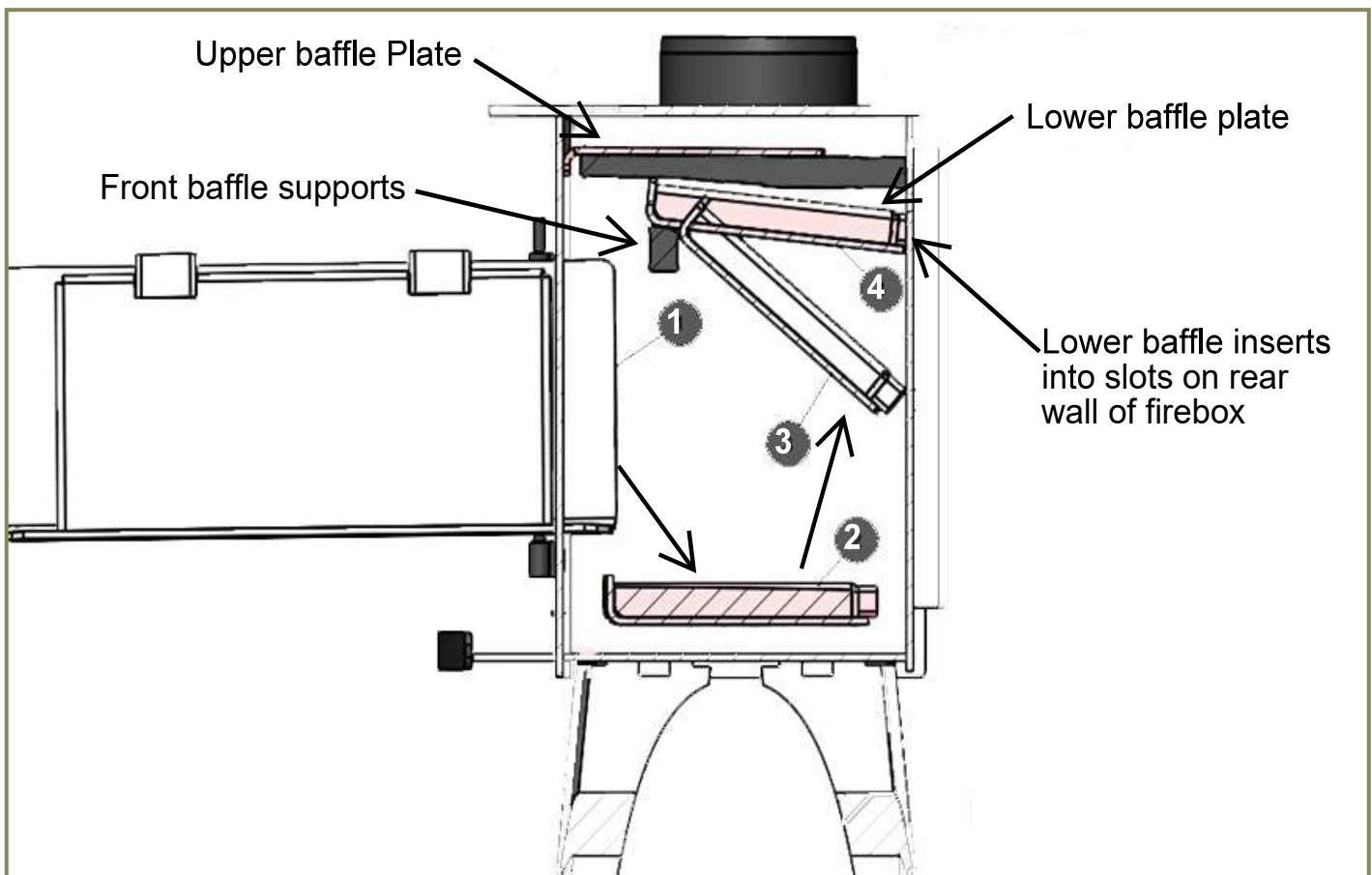

Installation

Firebrick Installation, Care & Maintenance

Fitting the Firebricks and Firebrick Retainer

Your Eureka Jade requires firebricks to be installed to ensure that the fire operates correctly, and to prevent damage to the firebox through excessive heat.

This fireplace uses two different size firebricks. Please use Table B and Figure 5 below to differentiate between each brick and its installation location.

Fitment is as follows:

1. Feed the firebrick retainer into the firebox, so that the long edge faces towards the rear of the firebox, with the flat face pointing up.
2. Lifting up the firebrick retainer with one hand feed 1x brick 'A' and 1x brick 'B' into the right hand side of the firebox, as illustrated below in Figure 5. Ensure the bevelled edge of the firebricks are facing down and towards the outside of the firebox. Ensure these brick are pressed firmly against the outside face of the firebox.
3. Lifting up the firebrick retainer, feed 3x brick 'A' into the rear of the firebox. Once all bricks are orientated as shown in Figure 5 below, slide them all firmly to the right hand side of the firebox.
4. Feed 1x brick 'A' and 1x brick 'B' into the left hand side of the firebox as orientated in Figure 4 below, and ensure they are slid firmly against the rear bricks in the firebox.
5. Ensure that the firebrick retainer is sitting securely in position over the firebricks.

Removal of the firebricks and retainer is carried out in reverse order of installation.

Table B - Firebricks			
Designation	Width	Length	QTY
A	160	255	5
B	80	255	2

Firebrick Re-order P/N - 236260

Figure 5: Firebrick Installation

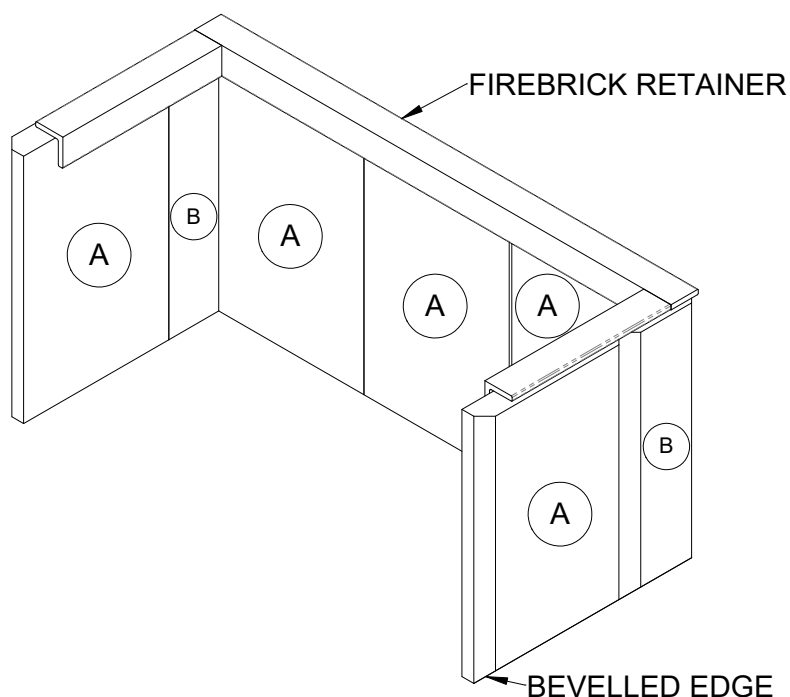

Installation

Flue and chimney requirements

The flue pipe shall extend not less than 4.6m above the top of the floor protector. Installation must be carried out by a licensed installer in accordance with AS/NZS 2918:2018 (AS2918 Extracts below illustrate minimum flue clearances).

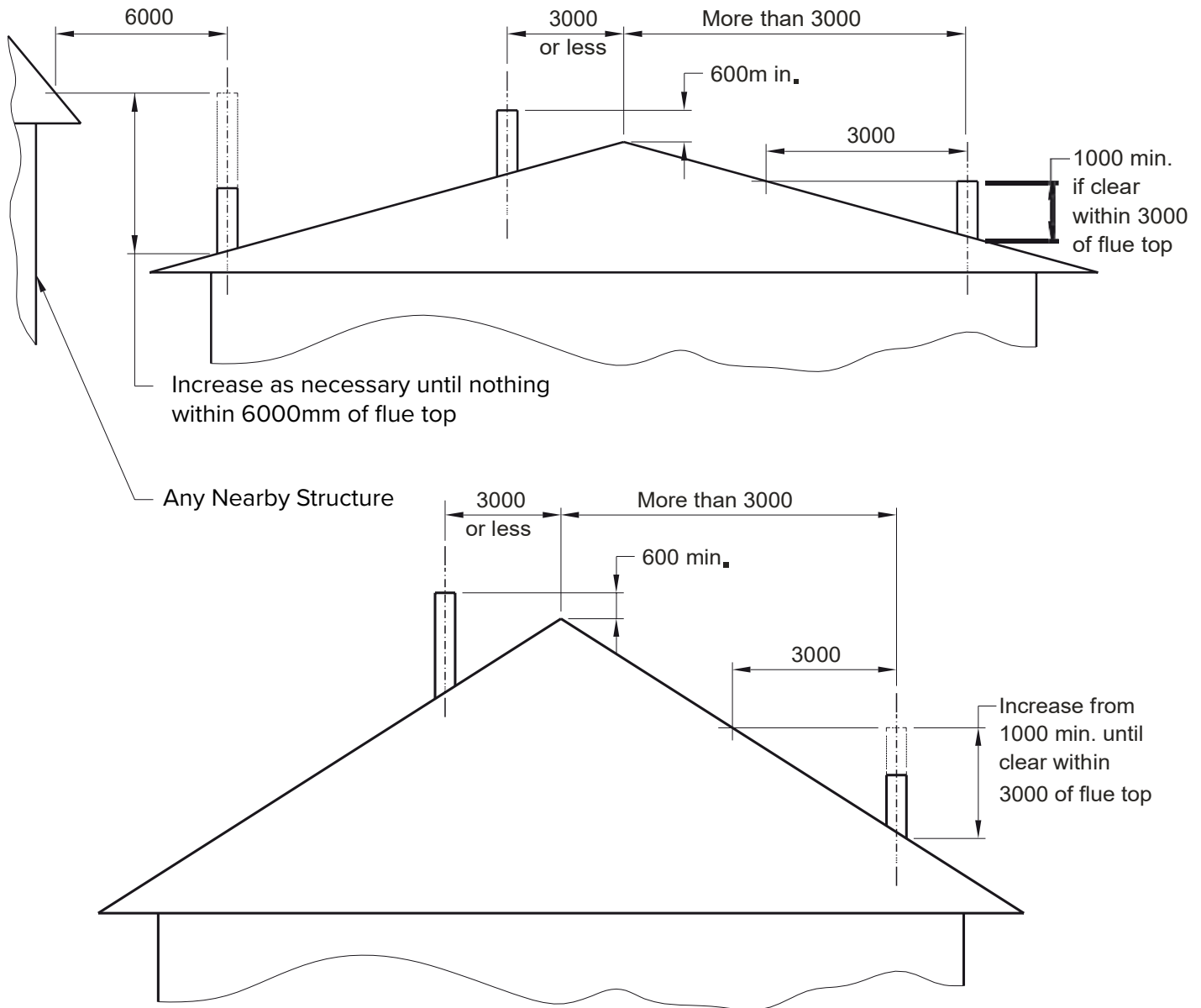

DIMENSIONS IN MILLIMETRES

AS2918 SECTION 4.9.1 : FIGURE 4.8 MINIMUM HEIGHT OF FLUE SYSTEM EXIT

Installation

Fitting or Removing the Door

Exercise caution when handling the door assembly, as it is bulky and heavy. Fitment is as follows:

1. Stand the door up so that is vertical, in the same orientation that it will be fitted to the heater.
2. Hold the door at between 45 and 90 degrees from the door opening, positioning the hinges over the hinge pins on the firebox.
3. Lower the door so that the hinges locate on the hinge pins, ensuring that you do not let go until you are certain that the hinges are correctly located.
4. Open and close the door (several times if necessary) to check the door has located on the hinge correctly and is aligned centrally on the firebox.
5. Visually check there are no gaps between door rope & front of heater - adjust door handle if required. (see page 12)

Removal of the door is carried out in reverse order of installation. Take care not to damage the door rope when removing or reinstalling the door.

Final Inspection Prior to Use

Before lighting the first fire in your new Eureka wood heater, check the following list of items to ensure that your heater will perform correctly, and safely:

- Ensure the baffle plates are installed correctly and securely fitted.
- Ensure that the firebricks are installed correctly with their retainer.
- Ensure the door is correctly fitted, and that the door catch can be engaged/disengaged as required.
- Check that the air slide can be operated within it's full range (8mm gap in closed position)
- Check that the door seals are in place and fitting correctly.

Operating your Eureka



WARNING

GENERAL OPERATION

DO NOT ATTEMPT TO OPERATE THIS APPLIANCE WITHOUT READING AND UNDERSTANDING THESE OPERATING INSTRUCTIONS THOROUGHLY. FAILURE TO OPERATE THIS APPLIANCE CORRECTLY MAY RESULT IN DAMAGE TO THE APPLIANCE OR RESULT IN A FLUE FIRE.

Features and operating methods may not be typical of all wood heaters. As such it is imperative that you read and understand these instructions, and operate the heater accordingly. Failure to do so is likely to result in poor performance of the unit, and may present a safety risk to the user.

If firebox failure is reported and it is found that the firebox has been abused. AF Gason Pty. Ltd. reserve the right to disallow any warranty claims in relation to firebox failure

DOOR SAFETY

Leaving door open 10mm on initial start up encourages the fire to pick up at a faster rate. Your heater has been tested to ensure that no structural damage can take place if the door is inadvertently left open. However your paint finish can be damaged if the door is left open for a long period with a full firebox of fuel.

Closely supervise your heater while the door is left open.

Always ensure that before you close your door there is no wood protruding beyond the front of the firebox opening. Do not use the door glass to push the wood back into the firebox. Damage to the glass by such impact is not covered by your warranty.

Building your Fire

Place a firelighter in the bottom of the firebox near the centre, then place a large amount of dry kindling in a criss-cross pattern, such that the pile is at least half the height of the firebox. Kindling pieces should be around 2cm thick, and around 25cm long. On top of the kindling, place 3-4 larger wood pieces, around 6cm thick and 25cm long. Building your fire in this manner ensures that it will get going quickly and provide you with warmth sooner and assist in a cleaner burn. Attempting to light a fire with small quantities of kindling will more than likely generate excessive smoke and prolong the start-up process.

Lighting your Fire

- Ensure that the air slide is fully open.
- Ignite the firelighter you have placed underneath the kindling, and close the door once ignition has begun.
- Close the door once the newly lit fire is self sustaining. (Do not leave heater unsupervised with door open)
- After around 20 minutes or once the fire is established, adjust the air slide position to suit your desired heat output from the fire.
- Repeat during reloading

On the initial fire up you may detect smoke coming from the paint finish, and from any oils that may be impregnated in the steel of the firebox. This is normal. It is suggested to well ventilate your home on the initial fire up. During the initial fire up, the upper air slide should only be opened to half way once the fire has been established. Please refer to our instructions on "Paint Curing & Care" on page 2.

Operating the door:

To open the door rotate the handle 90 degrees counter-clockwise, and pull outward. To close the door, push the door shut and rotate the handle 90 degrees clockwise. The door should swing freely during both operations; if it does not, consult your Eureka dealer.

Operating your Eureka

The door should remain closed during operation, except for when you are lighting or re-fueling your fire. The heater is unable to circulate air inside the firebox effectively with the door open, and extended periods of the door being open during operation can result in smoke escaping into the room. Operating your heater with the door open for extended periods of time constitutes misuse, and AF Gason Pty. Ltd. will not be held liable for any resultant damage.

Daily Operations

When refuelling during normal operation it may help reduce smoking to leave the air slide fully open for approximately 10-15 minutes to ensure the fire is well established before closing down the air slide to the desired level.

Keep in mind that each piece of wood contains a finite amount of energy. Feeding more air to the fire by leaving the air slide open, will allow the fire to burn hotter and cleaner than with the air slide closed, as more energy is able to be released as heat at the same time. This means that with the air slide open, each piece of wood will also burn for shorter periods of time than with the air slide closed, meaning you will need to re-fuel your fire more frequently.

For best results, you should burn hardwood logs around 9cm - 15cm in diameter, and 20cm long, with a moisture content between 14% - 16%. Place the logs facing front to rear in the firebox, as this will promote good air circulation around them, and prevent the logs from rolling forward against the door glass while burning.

Long Burn

Approximately 30 minutes before turning the heater down for overnight burn it is recommended to load the heater with larger pieces of wood. Leave the air slide in the open position, and let the heater run for 30 minutes. This will reduce the moisture content in the wood before shut down, helping to reduce the formation of creosote in the firebox and flue. Set the air control to the setting you have found best for your requirements, and retire for the evening. It is important that you understand that modern heaters cannot be shut down overnight as easily as older heaters. The reason for this is that when heaters are shut down too much for long burns, the fuel is starved of air which leads to excessive smoke emissions and creosote formation within the firebox and flue. All new wood heaters are subject to the restrictions of modern emissions and efficiency standards, which have been put in place to minimise the impact of particulate emissions from wood heaters. Ensuring that you select large pieces of good wood to shut down overnight with, maintain a sufficient ash bed, and following the instructions in this manual are all important factors in achieving a successful overnight burn. The aim when completing a long burn is to have only a few hot embers left in the bottom of the firebox in the morning, not large lumps of wood.

Understanding your Heater

Your wood heater was designed to meet and exceed the emissions and efficiency requirements of Australian & New Zealand standards AS/NZS 4012 & AS/NZS 4013. This standard was established to reduce emissions, lower wood consumption, and ensure that wood heating remains a viable source of heat for Australians moving forward. As a result of this, your heater may perform differently to older heaters that you may be familiar with.

Modern wood heaters can be more sensitive to poor quality wood, as well as installation factors such as flue set-up, and pressure differentials between the inside of your house and outside. See the troubleshooting section of this manual if you are having difficulty getting your heater to perform properly, or contact the dealer from whom you purchased the heater, who will be able to assist you and offer advice on getting your heater to run properly.

Maintaining & Servicing your Eureka



WARNING

IT IS RECOMMENDED THAT YOU SEEK THE SERVICES OF A LICENSED PLUMBER TO CARRY OUT FLUE MAINTENANCE.

THE BAFFLE SYSTEM IS A CRITICAL PART OF YOUR HEATER. IF THE BAFFLE SYSTEM IS DAMAGED, BURNT OUT, DISCARDED, OR NOT INSTALLED AS PER THESE INSTRUCTIONS, POOR PERFORMANCE AND EXCESSIVE FIRE-BOX AND FLUE TEMPERATURES CAN RESULT.

IF FIREBOX FAILURE, FLUE FAILURE, OR EXCESS DAMAGE TO THE APPLIANCE OR ITS SURROUNDINGS IS REPORTED DUE TO INCORRECT INSTALLATION OR OPERATION OF THE BAFFLE SYSTEM, AF GASON PTY. LTD. RESERVES THE RIGHT TO DISALLOW ANY WARRANTY CLAIMS IN RELATION TO THE ABOVEMENTIONED.

Cleaning your Flue

It is recommended that you seek the services of a professional to carry out flue maintenance.

Firstly carefully remove the bricks, brick retainer and firebox baffles following the instructions given on pages 5,6 & 7. Close the heater door. Obtain a 150mm flue brush from you local Eureka dealer. Proceed to a position where you can access the flue cowl, and remove it from the flue. Follow the instructions provided with your flue brush to assemble it, slowly push the brush down the chimney until it stops. Pull the brush back through and repeat the process. Each time you do this, you will notice the brush will go further down the chimney until it reaches the bottom, as the dislodged soot and creosote falls down the chimney into the firebox. Ensure that you re-fit the flue cowl when you have finished cleaning the flue. Clean the residue from the firebox and re-fit the baffles and other components, as per the instructions in the relevant sections of this manual. Make sure the flue is cleaned thoroughly, as creosote will take longer to re-form in a well cleaned flue compared to one left with residual creosote build up.

Inspecting the Baffles

It is recommended that your heater baffles be inspected at least once a year, more often if your heater is operated for more than six months of the year. A convenient time to do this is when your are cleaning the flue.

The baffles should be free from deformation or bowing, and there should be no holes in the steel (excluding the tertiary air slots in the Lower baffle). If the baffles are compromised in any way, they should be replaced. Operating your heater with defective baffles will lead to losses in efficiency and heat output, and will also lead to high flue temperatures. Operating your heater with a compromised baffle system, or without either of the baffles, will likely result in premature wear of the heater, and is deemed to be misuse of the appliance.

Maintaining the Door Seal

To maintain efficient and safe use of your Eureka wood heater, you may need to adjust the door handle tightness. It is important that you periodically check the door seal, to ensure that it is sealing against the face of the firebox at all points when the door is in the closed position. If the door seal is excessively worn or damaged and unable to seal adequately, you will need to replace it.

Adjusting the Door Handle

Referring to Figure 7 on Page 17, remove the first nut, washers and latch wing from the handle.

Adjust sequence of washers to space the latch wing further in or out as required and reinstall the nut and tighten firm.

Maintaining & Servicing your Eureka

Fitting a New Door Seal

- Remove the door from the wood heater (See “Fitting or Removing the Door” in the installation section above)
- Place the door face down on a soft flat surface to protect paintwork and glass.
- Remove the old door rope and scrape the rope channel free from residual glue.
- Clean the rope retaining channel with a clean dry cloth, to remove any dust and debris. The use of wax and grease remover may be necessary if the channel is particularly dirty.
- Apply a generous bead of high-temp silicone around the rope retaining channel.
- Press the new 16mm diameter 1.5m length of door rope into the rope retaining channel, placing the start-stop joint in the middle of the door on the hinge side. Ensure it is installed evenly.
- Re-fit the door to the heater and close the door, to apply pressure to the rope while the silicone cures.

Note: The door handle may need to be adjusted to allow the door to close completely if previously adjusted to accommodate an aging rope. Leave the door closed for at least 12 hours before lighting the heater, and initially run at a low temperature to allow the adhesive to fully bond to the door.

Cleaning the Glass

Generally the only time you may need to clean your glass is after a long overnight burn. If you find that you have a wet sticky black film on your glass (creosote), it is best to burn the heater as normal for a load of wood or two, allowing it to then extinguish with the upper air slide fully open. This should burn the moisture out of the creosote build up and clean the majority of it away through the air circulation from the air wash, leaving you with a lighter dry build up of ash on the glass. Once the door has cooled to a temperature that you can touch it comfortably, use a damp cloth with water or glass cleaner, wipe the glass clean. You should not need to use a scraper or abrasives to clean the glass. If you have difficulty getting the glass clean, try using wet ash from the firebox and newspaper to scrub the glass, before wiping it clean with the damp cloth.

Creosote on the glass is normally a sign that the heater has been shut down too early after loading, or for too long. It can also be an indicator that you have burnt excessively wet or green wood. Refer to our troubleshooting section for more information on this.

Important: Ensure glass cleaner if used does not come into contact with the paint work.

Replacing the Door Glass

- Remove the door from the wood heater (See “Fitting or Removing the Door” on page 9)
- Place the door face down on a soft flat surface to protect paintwork and glass.
- Remove door rope from channel on airslide.
- Remove air slide knob.
- Remove the 2 outer screws on the airslide assembly and remove airslide
- Remove 4 remaining screws to remove upper and lower glass retainers.
- Ensure glass has tape applied evenly all around the outer edge with the tape join in the bottom corner.
- Re-fit the door to the heater referring again to the “Fitting or Removing of Door” instructions on page 9, ensuring that the door is kept closed long enough for the silicone to cure if needed.

Troubleshooting

Heater Emitting Smoke while door open

- It is normal for your wood burning heater to emit a certain amount of smoke when the door is opened during operation. Smoke will move in the path of least resistance as it rises from the fire, and when your heater door is opened, the opening becomes that path of least resistance.
- It is important that you adhere to the instructions in this manual, and that the heater is operated with the door closed at all times, except for when you are lighting the fire, or refuelling.
- A sluggish or lazy fire will generate more smoke than an active hot fire. If you have shut your fire down for a long burn, more smoke will be generated when you open the door.
- If you find that your fire is emitting noticeable amounts of smoke into the room during normal operation, or excessive amounts of smoke when the door is opened, check that the baffles are correctly fitted and in good condition, and that there are no other visible defects with the heater. If there is no problem found with the heater itself, there is more than likely a problem with your flue system and you should have it inspected by a plumber for blockages or downdraft.

Excessive Ash Build Up

- Different types of wood will generate different amounts of coals and ash, depending on its composition and on how you use the heater. Given the variety of wood available in Australia, you will need to determine which wood is available to you that best suits the heater.
- All testing and certification for wood heaters sold in Australia is carried out using seasoned River Red Gum, which is an energy dense hardwood. Red Gum burns hot with large coals that reduce to very little ash, and is the recommended wood in ideal circumstances.
- Depending on what wood is available to you, you may find that your firebox builds up with ash more quickly than desired. This is unfortunately a function of the wood being burnt, not the heater itself.
- Ensure your wood is well seasoned and not overly sappy. Good hardwood with moisture content below 16% is ideal.
- Burning bark will generate excessive ash, try to avoid burning it.
- Consistently running your fire with the air slides shut down will generate excessive coals and ash, as well as creosote build up. Burning a hot fire will help to reduce these back down after a couple of cycles.
- We recommend leaving your air slide fully open for approx. 20-30mins after reloading the firebox.

Short Burn times

- Check that the air slides are not stuck open, and that the air slide assembly is fixed securely to the door.
- Ensure that the baffles are correctly installed and are free from any damage, the upper baffle needs to be pushed fully forward against front of firebox and the lower baffle needs to be against rear of firebox.
- Ensure that the door rope is sealing against the door opening, all the way around the door opening. This can be checked by placing a strip of paper between the door and the firebox and closing the door, then checking to see if the paper is clamped in place or free to move. If the paper is free to move, you will need to inspect your door seal and either replace the rope or adjust your door catch.
- Ensure that you have a reasonable ash bed in the base of your firebox. The ash bed acts as a heat store, and helps to maintain hot coals once the fire has burnt low.
- Ensure that you are loading your fire with good quality hardwood, and in sufficient quantities for an overnight burn. You should try to fill the firebox as much as possible when loading for an overnight burn, with large logs at least 15cm in diameter.
- Round logs with smooth outer surfaces tend to take longer to burn when compared to logs that have been split from larger pieces and have exposed rough surfaces.

Troubleshooting

Sluggish or Lazy Fire

- Check that the baffle plates are installed correctly and there is no build up on baffle plates.
- A sluggish or lazy fire can be caused by a number of different factors, or a combination of several factors.
- Ensure that the wood you are burning is of good quality, and has been well seasoned to ensure its moisture content is below 16%. Overly wet wood will cool the fire, smoke excessively, and cause your unit to run poorly. The best way to determine the moisture content of your wood is to use a digital moisture meter. Wood that looks dry on the outside can still be high in moisture on the inside.
- Ensure that there is not a negative pressure inside your house. Wood burning fires consume air as part of the combustion process. They need a constant supply of air to function correctly. If your home is overly sealed and air is unable to get to the fire as needed, it will create a negative pressure inside the house compared to the outside, which will cause your fire to smoke and run poorly. Running extraction fans in your kitchen or bathroom can also impact on this in well sealed modern homes. The best way to test for this is to try opening an external door or window near the heater while it is running, to determine whether it runs better with ready access to outside air.
- Non-standard flue installations can also cause your fire to run poorly if not correctly installed. The addition of bends and elbows in the flue will restrict the flow of flue gasses more than normal, meaning that you may need to fit an additional length of flue in order for your heater to draw properly.
- Environmental factors such as consistent wind, structures or vegetation near the flue outlet, or other unforeseen factors can have a dramatic impact on the performance of your heater. These can usually be overcome by fitting an extra length of flue, or through the fitment of a specialty cowl such as a wind chaser or a vertical discharge cowl.
- Ensure you are putting enough wood in your fire. Modern fireplaces are designed to run hotter and cleaner than older designs. This means that they perform best when they are well stocked with wood and have a hefty bed of hot coals. You will become familiar with the unit as you use it, and learn what sort of operation best suits your needs and wood type. As a general rule it is best to start out by building a big fire and then reducing the fuel load to a level that you find suitable for your needs. This allows the flue to reach an appropriate operating temperature for it to draw properly from the beginning, which will promote an active fire and good heat output.

Air Controls Jamming

- Check that there are no visible physical obstructions to the air slide, such as charcoal or wood.
- Try freeing the air slide using WD-40, or a similar lubricant. It may be necessary to remove the air slide assembly and gain access to the air slide in order to clean out any debris or contamination contributing to the jamming.

Firewood

Getting the most out of your Firewood

Firewood is a sustainable source of energy and when used correctly can provide a cost effective form of heating in your home. Too often poor heating results and operational issues are attributed to using unseasoned wood which leads to excess smoking, causing creosote buildup and dirty glass. Wood should be stored in a dry place where good ventilation is available. Freshly cut wood should be stored for between 12-24 months before burning. Use only hardwood with your Eureka wood heater.

Thermal efficiency

A wood's efficiency does not depend only on its type, but also on its moisture content as well as the temperature of the combustion chamber. To achieve a greater efficiency and longer burn times out of your Eureka Jade without the emissions of hazardous particulates, your wood must be well seasoned.

Ideally, wood should not be burnt when its moisture content is above 20%. A moisture meter to measure moisture content is a handy addition.

An example of available thermal efficiency for a piece of wood as fuel source at varying moisture levels.

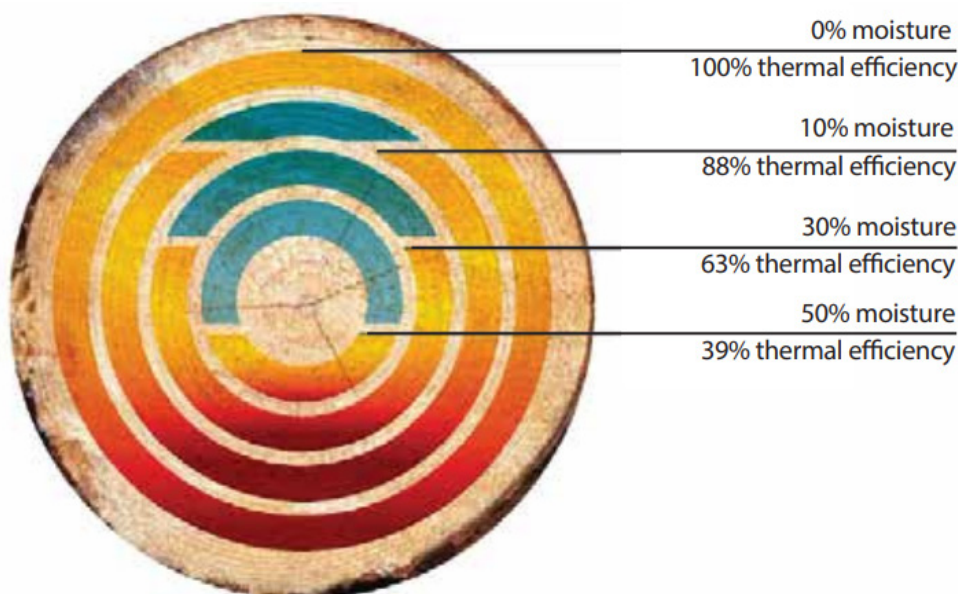

The combustion process of burning wood

When wood is heated up to approximately 100 degrees celsius, moisture begins to evaporate from the fuel. There is no heating value from the wood at this point. As moisture releases from the wood, it reduces the efficiency of the combustion process robbing heat energy from the wood. This demonstrates the importance of dry and well seasoned wood. As firebox temperatures reach 250-300 degrees celsius, wood solids begin to break down and release volatile gases which ignite and produce heat. From 300+ degrees celsius, the main energy available from wood is released when fuel vapors containing up to 60% of the wood's potential heat is released.

Understanding combustion principles and learning how to manipulate various conditions surrounding the operation of your Eureka wood heater enables you to achieve maximum comfort and efficiency from your Australian made wood heater.

Basic Spare Parts

Description	Gason P/N
Lower Baffle Plate	238833
Upper Baffle Plate	238835
Door Glass	236496
Door Assembly	238826
Door Handle assembly	238838
Ash Deflector	236257
Door rope (16mm OD, 1.5m Required)	203604
Firebrick set	236260
Brick retainer	236785
Door Handle	236505
Door Handle assembly kit	238838

***For any additional information or spare parts not listed above please contact your nearest dealer.*

Figure 7

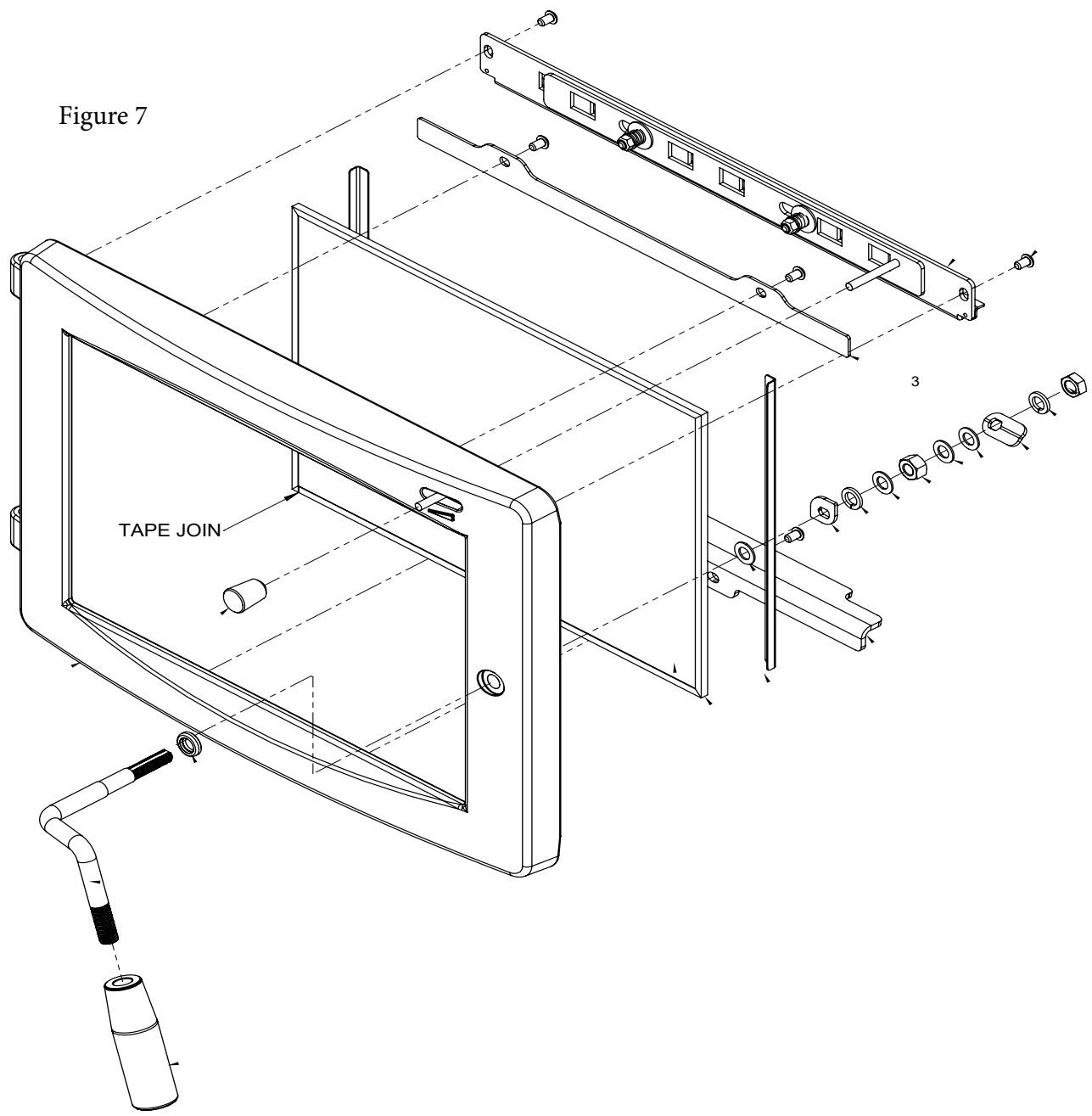



Scan the QR code to complete your warranty registration online.



WARRANTY

1. Subject to clauses 2 & 3 of this warranty, A.F. Gason Pty Ltd ACN 004 667 556 warrants the following components of its heaters against defects in workmanship and/or materials for the following periods from the date of purchase:

- a) the firebox for ten years;
- b) the paint finish for a period of 12 months if the purchaser has followed the instructions provided by Gason in the operation and Installation Instructions manual; and
- c) all other components for 12 months except the glass, firebrick lining or baffle plate if, in the opinion of Gason, these items have been damaged by impact.

2. This extended warranty does not apply;

- a) if the heater is purchased from a person who has not been authorised by Gason to sell its products;
- b) if, in the opinion of Gason, the heater or any other component has been subject to abuse, misuse, alteration, modification or has not been installed, operated or maintained in accordance with the instructions provided by Gason; or,
- c) to owners other than the original purchaser.

3. If you believe that the heater you purchased contains a manufacturing defect and you wish to make a claim under this warranty, please contact an authorised Gason service centre to arrange for an assessment.

4. If, after assessing the heater, Gason determines that the heater contains a manufacturing fault, Gason may at its discretion:

- a) replace the heater;
- b) repair or replace specific components of the heater; or
- c) provide a full refund.

5. Parts replaced under warranty are warranted for the balance of their original warranty period.

6. If, at the discretion of Gason, the heater or any part needs to be replaced, serviced or repaired at an authorised Gason service centre, then the person claiming under this warranty must pay all costs associated with:

- a) returning the heater; and
- b) the delivery or collection of any new or repaired heater.

Our goods come with guarantees that cannot be excluded under the Australian Consumer Law. You are entitled to a replacement or refund for a major failure and for compensation for any other reasonably foreseeable loss or damage. You are also entitled to have the goods repaired or replaced if the goods fail to be of acceptable quality and the failure does not amount to a major failure.

Any benefits you receive under these warranties are in addition to other rights and remedies that you may have as a consumer under law in relation to the heater to which these warranties relate.

These warranties are given by:

AF Gason Pty Ltd

29-31 Blake Street, Ararat VIC 3377

Please contact us if you have any queries on:

03 9763 2700 or email via the "Contact Us" section of the website.

