

IB1100 / 850 Gas Fire **escea.**

With Inset fascia option only

Information Sheet for Builders and Architects AU.

Creating the Cavity:

The dimensioned drawings below show the product dimensions and minimum size of the opening that must be created. The wall board that lines the outside of this opening can be normal dry wall (Gib Board) and does not need to be non-combustible. The flue and Outer Skin Kit (OSK) are installed first with power and gas services in place so that the fire itself can be installed quickly and easily once the room, into which it is installed, is complete. i.e. walls finished (painted/papered) and floor coverings in place.

Product Dimensions (Showing product fitted inside OSK): (mm)

Internal Cavity Dimensions: (mm)

	A	B	C	D	E min	F	G	H
IB850	965	565	565	995	36	960	480	985
IB1100	1265	565	565	1295	36	1260	630	1285

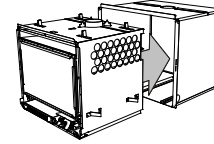

Abbey Fireplaces

Sydney
26 Roger Street
Brookvale, NSW 2100
Ph: 9339 9848
sales@thefireplace.com.au
www.thefireplace.com.au

South Coast
130 Industrial Road
Oak Flats, NSW 2529
Ph: 4256 5555

Oak Flats, NSW 2529
Ph: 4256 5555

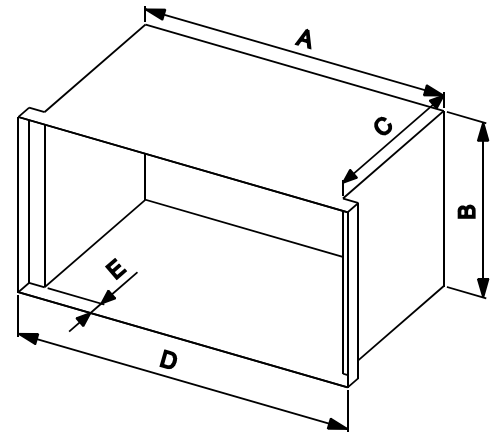
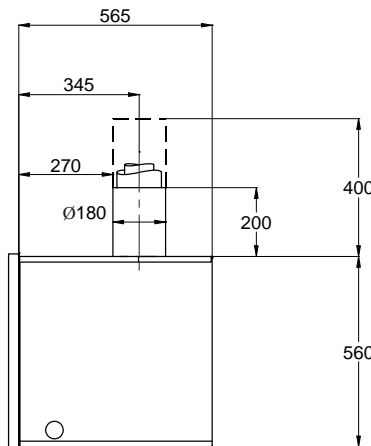
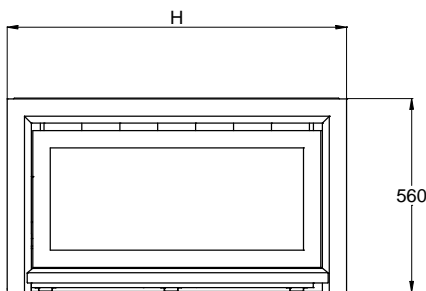
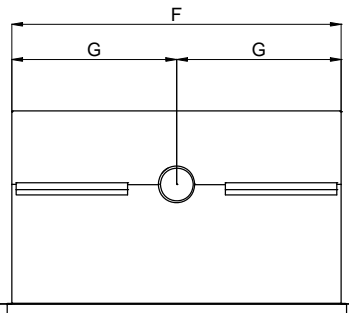

Order of installation:

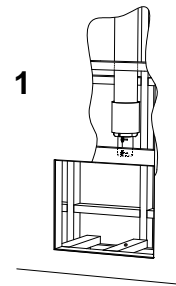

Cavity created and flue installed

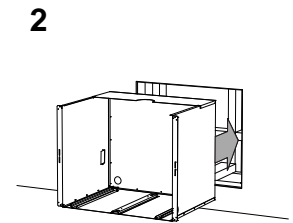

OSK fitted and gas & power services installed

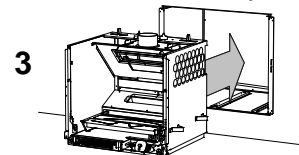

After the room/dwelling is complete finally install and commission the gas fireplace.

Flueing the heater:

This heater is to be conventionally flued with a 100mm dia flue system, in accordance with the requirements of AS5601 / AG601-2000.

Gas Specifications:

- Heat output IB850 = 7.5kW
- Heat output IB1100 = 7.9kW
- Gas Input = 40MJ/h
- Gas Connection = Front RH corner of heater
- Electrical Connection = 240V 3 Pin plug within 1.2m of the rear LH corner of heater

Ventilation:

It is **important to remember** that local building codes require additional ventilation be included into living spaces where open flued natural draught appliances are installed.

Your local building codes provide formulae and tables for calculating the required ventilation given the size of the living space and the gas input of the appliance.

The following are the recommended minimum clearances for the location of any electrical equipment (such as Plasma TV, LCD TV or home theatre) above an escea gas fire. Use either (1) a shelf or mantle below your TV screen or alternatively you can construct (2) a recess to mount your TV screen into.

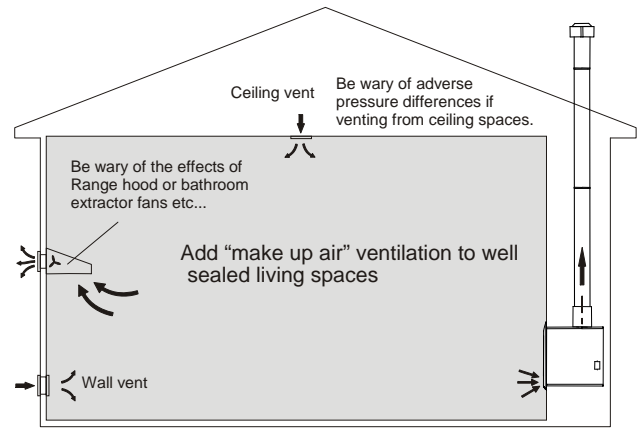

1. Protective Mantle

2. Recessed

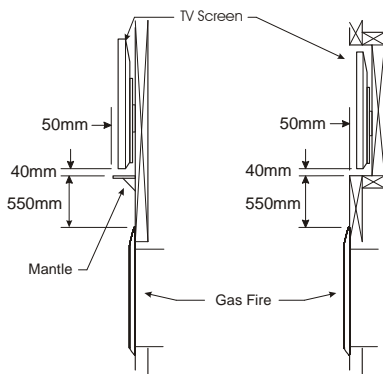

When building a recess the flueing must be considered. Shown right is the minimum distances possible when offsetting the flue to allow for a recess above.

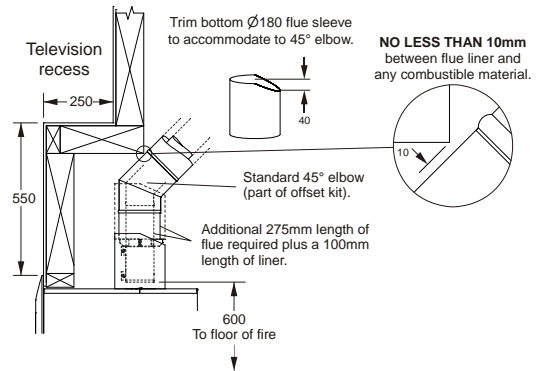

Floor of cavity:

The base of the product must be fully supported at either side and at the centre front to back.

Hearth:

This fire **must** be installed a minimum of 100mm off the floor. A raised hearth can be of any size, but must be constructed from non-combustible materials.

NOTE: If the hearth is to be covered with tiles or some other veneer then the fire must be installed so that the base of the 'Outer Skin Kit' is level with the finished top surface of the hearth.

Raising the fire up a wall:

If the fire is being located where its base is any more than **100mm** up off the ground, no hearth is required. Escea recommend using our four sided fascia. (Available from your Escea dealer).

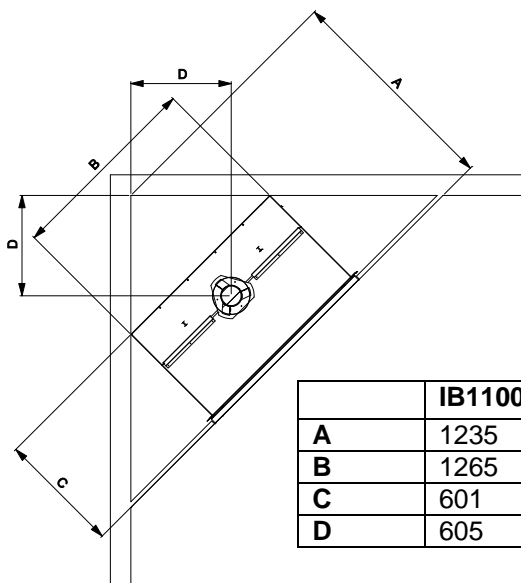

Corner Installations:

If a cavity is to be created in a corner the picture to the left gives the approximate minimum sized interior wall and resultant flue position.

	IB1100	IB850
A	1235	1075
B	1265	965
C	601	601
D	605	490

Mantle Clearance:

Please refer to diagram below. Mantles or protruding ledges mounted above the heater that are made from **combustible materials**, must not extend out side of the dimensions shown.

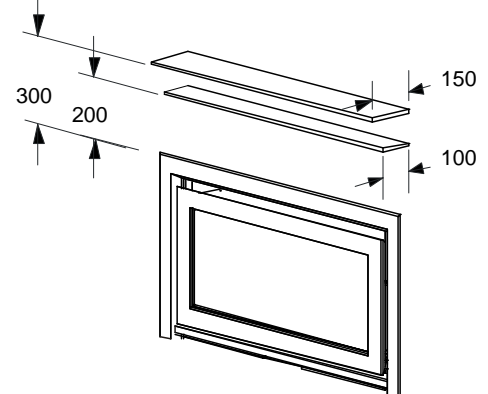

Manufactured by:
Escea Ltd New Zealand

Visit the Escea website for details of your local distributor
Web: www.escea.com.au