

# escea.

**Abbey  
Fireplaces**

Sydney  
26 Roger Street  
Brookvale, NSW 2100  
Ph: 9939 9948

South Coast  
136 Industrial Road  
Oak Flats, NSW 2529  
Ph: 4256 5555

[sales@thefireplace.com.au](mailto:sales@thefireplace.com.au)

[www.thefireplace.com.au](http://www.thefireplace.com.au)

IB1100 and IB850

# Service Manual

AUSTRALIAN EDITION



## Important

- This appliance **must** be serviced every 12 months.
- Any service operation should be carried out only by a suitably qualified and trained person
- Gas and electricity supply **MUST** be isolated before any service operation is carried out on this appliance.
- This manual must be left with the appliance.
- **DO NOT MODIFY THIS APPLIANCE**

Manufactured by: Escea Ltd, PO Box 5277 Dunedin NZ, Ph: +64 3 479 0302, email: [info@escea.com.au](mailto:info@escea.com.au)  
For contact details of your local escea distributor or dealer please visit [www.escea.com.au](http://www.escea.com.au)

Contents:	Page:
Error Codes	3
Cleaning the Log Set and Glass	5
Checking Operating Pressure	6
Removing / Cleaning Fan	7
Removing Electronic Drawer	8
Replacing a Wireless Control	9
Gas Type Conversion	10
Annual Service Procedure	11
Wiring Diagram	12





## Error Codes:





This gas fire has been designed to show error codes to help explain and identify any fault situation that occurs.

These codes will appear on the wireless control in the form of a large letter "E" with a number beside it. Codes can normally be reset by turning the heater off at the wall then on again.

The following table shows what each code means and possible ways to rectify the situation.

In the case of persistent or repeated shutdown errors, action must be taken immediately to find and repair the fault.

Error Code	Suggested action
 <p><b>PCB Over Temp</b> (Printed Circuit Board)</p>	<ul style="list-style-type: none"> <li>-Possibly outer fascia panel installed incorrectly.</li> <li>-May be symptomatic of impeded flue draw, such as an extractor fan operating elsewhere in the immediate vicinity</li> </ul> <p><b>Note:</b> This error has a permanent lock out and will require the unit to be reset 10 minutes after the initial error (turning the power to the fire off "at the wall" then on again after a few seconds).</p>
 <p><b>Flame Failure</b></p>	<p>The fire has tried to light three times and failed.</p> <ul style="list-style-type: none"> <li>- Check gas supply and check other gas appliances to see if they are affected. If you have two separate propane cylinders, switch over to the full bottle or contact your gas supplier. You may need to retry igniting the fire a few times after re-establishing gas supply.</li> <li>- Check the electrode placement in relation to the flame. Ensure it is well enveloped in flame as per the diagram in the installation instructions. Ensure no coals have dropped onto the ignition electrodes between the burners.</li> <li>- Ensure the electrodes are not contacting any metalwork including the burners and that they have the correct air gap. Check that the spark electrode is positioned in front of a port in the front burner.</li> <li>- Check that there has not been a significant reduction in pressure inside the house (such as an extractor fan in a nearby kitchen) which can pull flue gas back down through the firebox "snuffing" the flames.</li> </ul>
 <p>OR</p> 	<p>The bimetallic snap disk mounted on the hood of the draught diverter at the rear of the fire or on the lid of the fire has tripped. The possible causes for this could include:... A gust of wind pushing exhaust gases back down the flue OR a significant reduction in air pressure inside the house which is pulling exhaust gases back down the flue (such as a extractor fan in a nearby kitchen).</p> <p>If installed into a tight masonry cavity it may indicate that the whole installation is getting too hot and some additional ventilation into the cavity may be required.</p>

<p><b>Draught Diverter Bimetallic Trip</b></p>	<p>In the unlikely event that the fans have stalled, and the snap disk on the lid of the fire has tripped, this would show an E3 also. Simply check that the fans are running normally after resetting and running the fire again.</p> <p><b>Note:</b> This error has a permanent lock out and will require the unit to be reset 10 minutes after the initial error (turning the power to the fire off "at the wall" then on again after a few seconds).</p>
<p> <b>Valve Solenoid Check Failure</b></p>	<p>The valve solenoids have failed the pre-ignition test. This is to detect a faulty valve solenoid. However, it is possible that some of the wiring connections between the resistors and the solenoids are not secure, or a wire has dislodged. Check that the connections to each solenoid and resistor are secure and in place. It may be that the connections on the ends of the wires need to be tightened a little (eg with a pair of pliers) to ensure a robust connection to the valve or resistor terminal.</p> <p>It could also be that one of the solenoids on the valve inside the fire have failed. If this is the case the valve will need to be replaced.</p>
<p> <b>Remote cannot communicate with fire</b></p>	<p>The remote cannot communicate with the fire. Reasons for this could include the fire being off "at the wall" i.e. a loss of power to the fire or the remote is outside of its effective radio frequency range (too far away from the fire). Typical remote range is 1m to 12m. Ensure there is power to the fire by pressing the auxiliary on/off (red) button on the fire, then press the on/off button on the remote to clear the error.</p>
<p> <b>Valve Temp Sensor Trip</b></p>	<p>The valve temperature sensor has detected abnormally high temperatures around the valves. This is an unlikely fault and should it occur please contact the Escea agent you purchased the fire from.</p> <p><b>Note:</b> This error has a permanent lock out and will require the unit to be reset 10 minutes after the initial error (turning the power to the fire off "at the wall" then on again after a few seconds).</p>
<p> <b>Temp Sensor Error</b></p>	<p>This indicates a fault with one of the two temperature sensors installed in your fire. Resetting the fire (turning the power to the fire off then on again after a few seconds) and if the fault reappears, please contact your Escea sales agent to organise a replacement sensor. These sensors must not be disabled or bypassed.</p> <p><b>Note:</b> This error has a permanent lock out and will require the unit to be reset 10 minutes after the initial error (turning the power to the fire off "at the wall" then on again after a few seconds).</p>

## Cleaning the Fascia, Log Set and Glass:

**NEVER RUB THE FASCIA.** The outside of the fascias must only be cleaned with a clean damp cloth, dry off after cleaning. The high temp silver powder coating that is used on Escea fascia parts contains certain amounts of aluminium that when rubbed too hard will oxidise leaving a black smudge that cannot be removed. Always clean when cold.

This is a service procedure that will need to be carried out when ever soot builds up on logs and/or inside of glass.

If soot build up becomes excessive or regular then one of the following actions may be required;

- Reset gas pressure, pressure may be too high;
- Reposition log set so that front edge of each log is just behind each row of holes in burner top;
- Clear any blockage from primary air port of burner;
- Check to make sure flue system is drawing well or that there are no adverse environmental conditions inhibiting clean combustion.

**Step 1:** Lift off the inner fascia by removing the screws attaching the bottom of the fascia to the firebox and lifting it up and off.

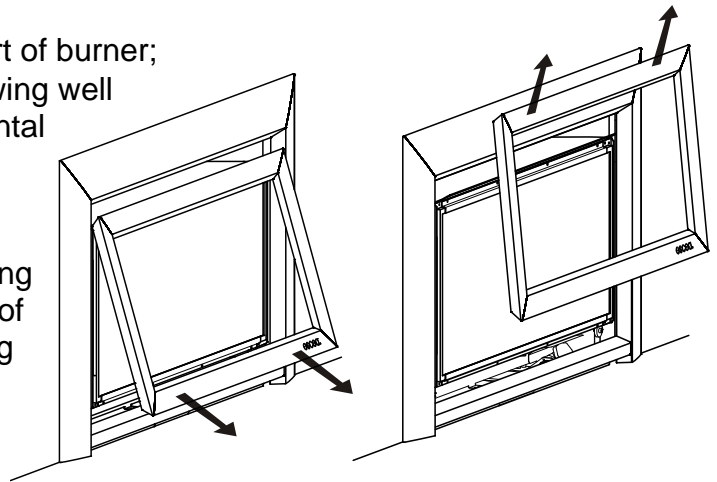

**Step 2:** Unscrew the top glass retainer and remove it. Take care that the glass does not fall forwards at this stage.

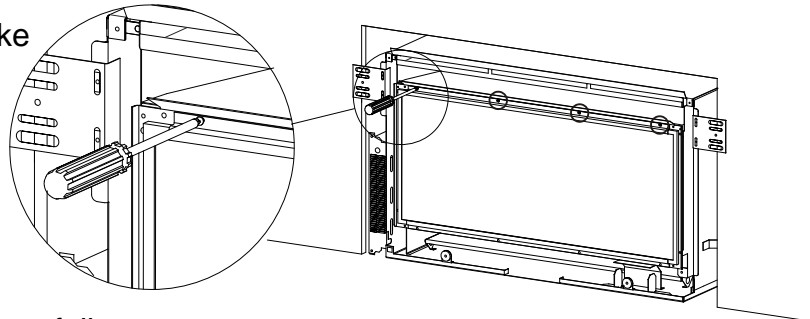

**Step 3:** Lift out glass and place it carefully aside.

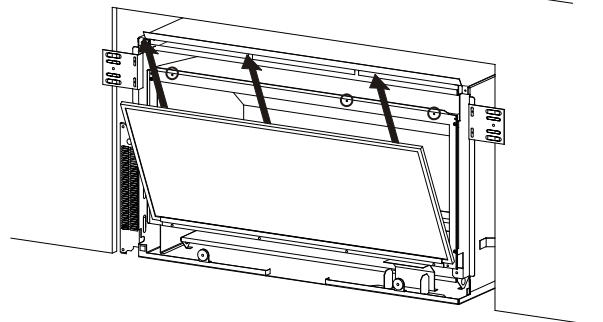

**Step 4:** Clean the inside and outside of glass with normal glass cleaning products. Use a **CLEAN DRY** cloth to remove cleaner residue. Stubborn marks may be cleaned with a ceramic glass cleaner.

**Step 5:** Take out log set and gently brush any soot from log with a soft hearth brush. The burner tops can be vacuumed to remove any excess material.

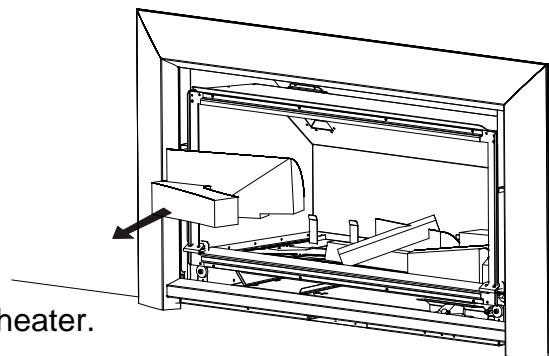

**Step 6:** Replace in opposite order and test run heater.

## Checking Operating Pressure:

This is done at the regulator located at the front RH corner of the appliance.

This is best done before the fascia panels have been fitted to avoid fascia damage. A pressure test point is available for the operating test pressure only (as shown below).

- 1) Check the inlet pressure to the appliance. Attach manometer tube to the first test point upstream of the appliance (typically at the gas utility meter or auto change device for a propane bottle station)
- 2) Run the heater on full (all three burners for IB850 and two burners for IB1100 are running) and measure inlet pressure. If pressure does not fall within the maximum or minimum pressures listed on the table below then reassess installation pipe size or upstream regulator settings.
- 3) Remove the operating pressure test point screw. Connect manometer tube and measure pressure with heater running on full (all three burners for IB850 and two burners for IB1100 are running).
- 4) The heater regulator pressure has been factory set to 0.87kPa for Natural Gas heaters and 2.30Kpa for LPG (PROPANE) heaters. Please check that the operating pressure is exactly as listed and if not, adjust screw in centre of regulator until pressure is correct.
- 5) Replace operating test point screw and leak test both test points.

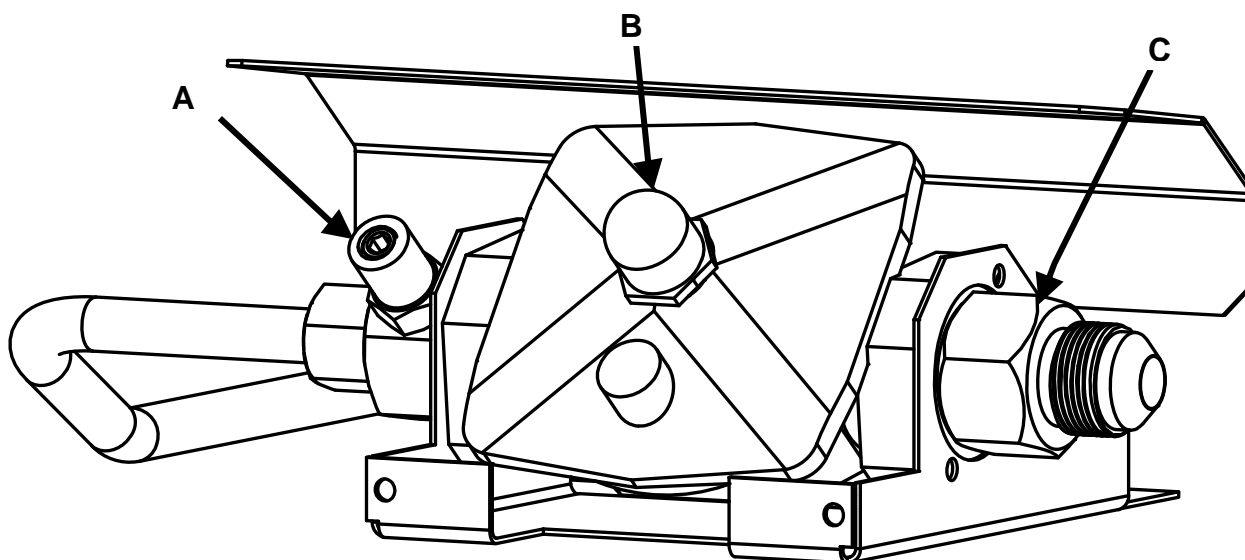

**A** = Operating Pressure test point

**B** = Pressure adjustment screw

**C** = Inlet gas connection

IB850 and IB1100 Pressure Table	Gas Type	
	PROPANE	Natural Gas
Minimum Inlet Pressure	2.5kPa	1.2kPa
Maximum Inlet Pressure	5.0kPa	5.0kPa
Operating Pressure	2.30kPa	0.87kPa



## Removing or Cleaning Fan

As part of regular service procedure, it is recommended that the fan is removed for cleaning. Dust will build up on the fan rotor and in the cavity where the fan is located. This can be removed by the service person using a hearth brush and a vacuum cleaner.

### Step One: ISOLATE THE POWER TO THE FIRE BEFORE PROCEDURE

Remove front glass, log set and log bracket as described on page 5. To remove the log bracket take out the screws securing it to the firebox.

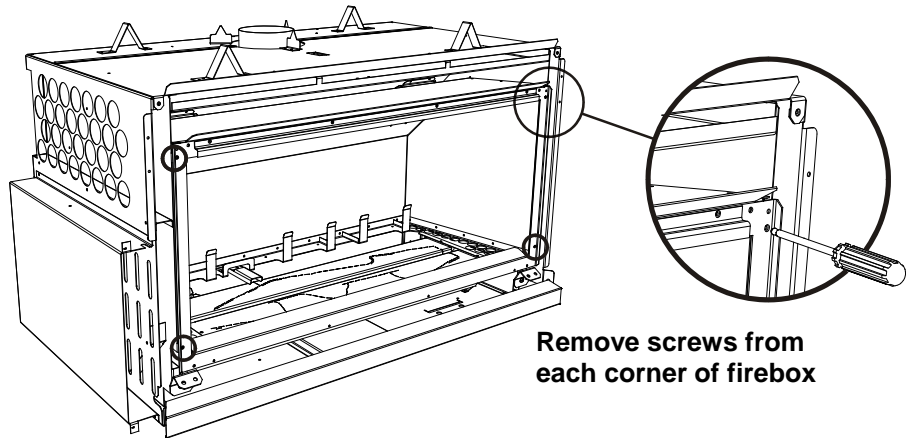

Remove screws from each corner of firebox

### Step Two:

Remove firebox from heater by taking out the two screws attaching the front lid + the screws in each corner of the firebox. Then remove the screws in the base of the firebox, and pull fire directly outwards (as shown).

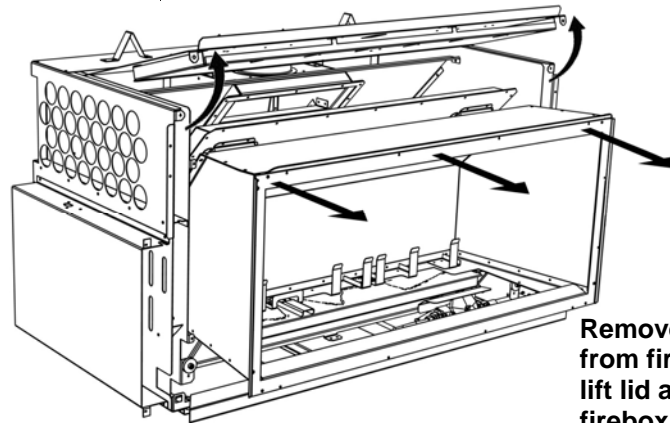

Remove screws from firebox base, lift lid and pull firebox out

### Step Three:

Take out the 7 screws on top of fan plate assembly.

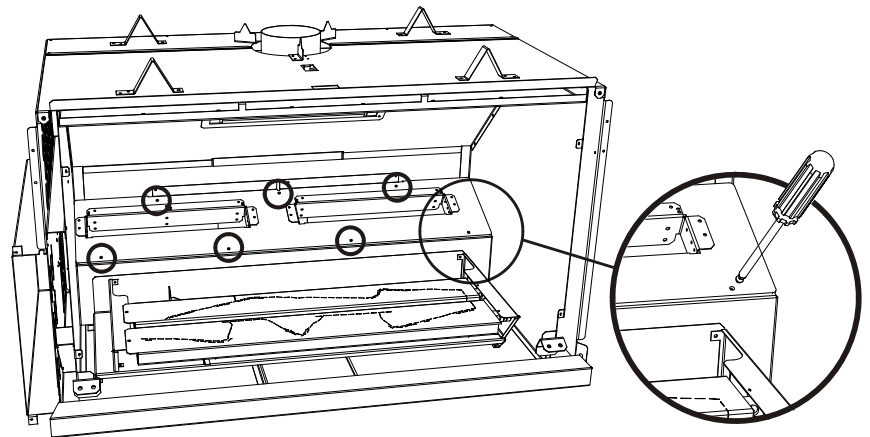

### Step Four:

Lift the fan unit up and out as far as the wiring loom will allow. Unplug wires to fully remove fan assembly.

### Step Five:

Clean fans and area around valves, removing all dust build up. Replace fans and fire box.

### Step Six:

To replace fan assembly and firebox repeat these steps in reverse order.

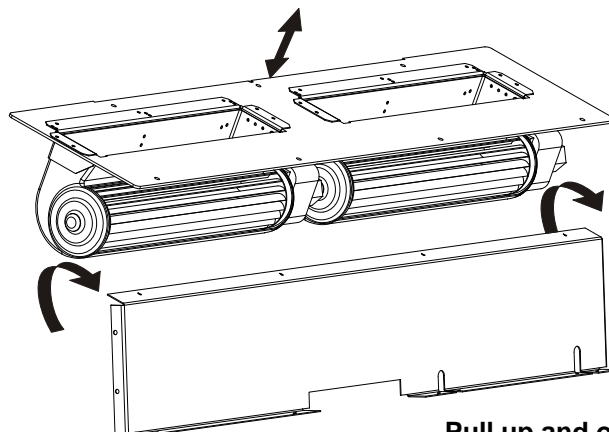

Pull up and outwards

# Replacing Electronic Drawer

## ISOLATE THE POWER TO THE FIRE BEFORE PROCEDURE.

All of the electronic components of the heater have been located on a removable drawer. This drawer is located on the left hand outer side of the IB850 and IB1100. On the back of the drawer are two large connectors that unplug as the drawer is removed so only the three wires connecting the electronics to the ignition and flame rods must be removed manually from the PCB (Printed Circuit Board).

**Step one:** Remove outer fascia by taking out two screws located behind the bottom fascia trim panel.

### Step Two:

Take out the two screws at each end of the electronic drawer and pull drawer directly outwards.

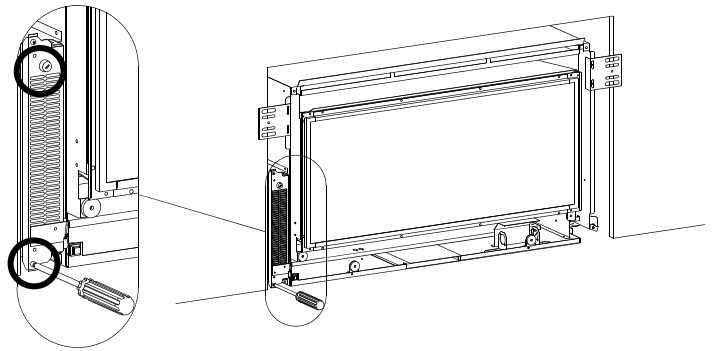

### Step Three:

Carefully remove the two wires shown from the white ignition module.

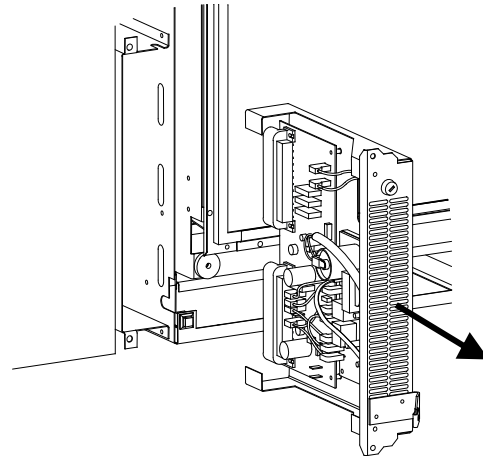

### Wire Entry:

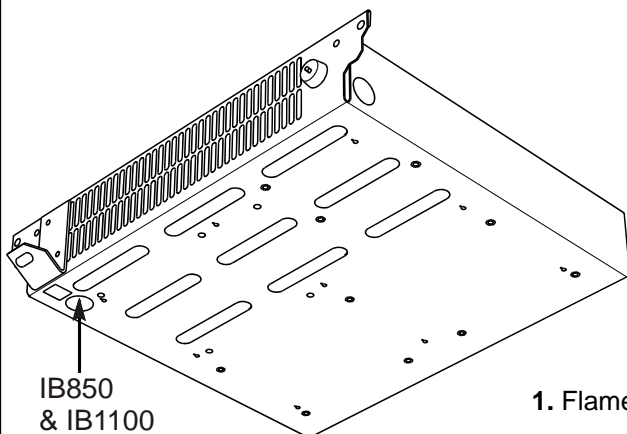

1. Flame Rod
2. Spark Lead

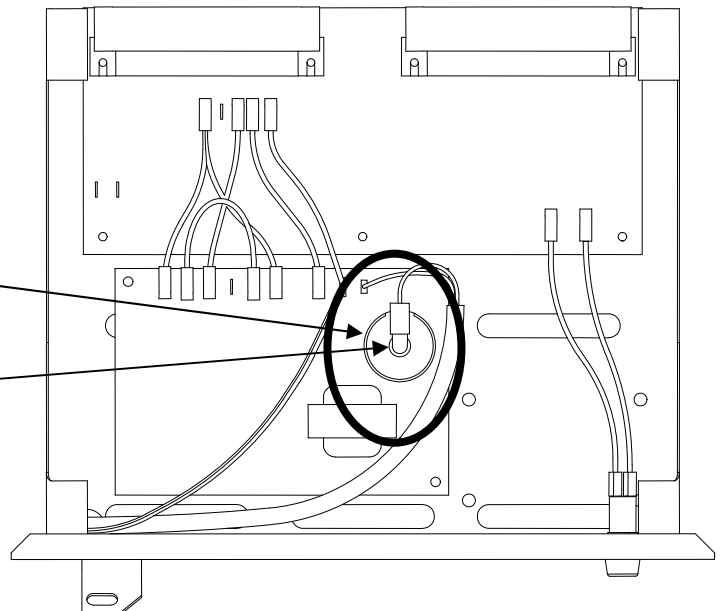

**Note:** It is important that the flame rod & spark lead wires sit in this position in the electronic tray.



## Replacing a Wireless Control:

If the wireless control becomes lost or damaged, a new one can be ordered from any Escea retail agent.

When you have the new remote, the following procedure needs to be followed to “teach” the remote to only communicate with that fire.

1. Ensure the fire and remote are set to “Off” (only the time is displayed on the remote).

2. Press the – (minus), + (plus) and the Fan Boost buttons simultaneously until all the characters on the display light up. This will put the remote into test mode and the two large temperature digits should be reading 00.

3. Press and hold the – (minus) button until the two large temperature digits reading 00 start to flash slowly. Release the – (minus) button. The remote control is now ready to be addressed to the fire.

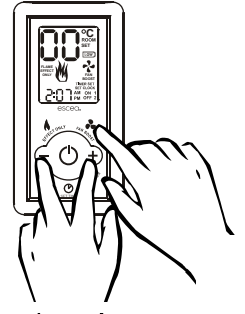

4. Press and hold the red auxiliary on/off button on the fireplace for a minimum of eight seconds, or until the two large temperature digits start counting upwards from 00 to 99 repeatedly.

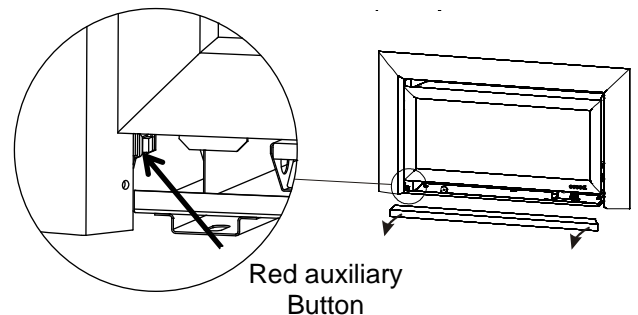

**Note:** Pressing the red auxiliary button on/off button will start the fire. Once the remote control is counting the fire can be turned off by pressing the red auxiliary button again.

5. Press the large power button in the middle of the remote control to exit the test mode and return to normal operation. The remote should only be displaying the time. Check the fire will start using the remote control by pressing the large power button. Turn it off again using the remote control.

6. The fire is now re-addressed to the remote control.

## Gas Type Conversion

Gas type conversion kits can be ordered from your Escea retailer under the following part numbers;

811220	Natural Gas Conversion Kit - IB850
811221	Propane Conversion Kit - IB850
811222	Natural Gas Conversion Kit - IB1100
811223	Propane Conversion Kit - IB1100

If the heater had not been used before gas type conversion was required then Escea will credit the cost of the conversion kit when the original parts are returned to Escea.

# Gas Type Conversion Procedure:

## Step One:

Remove inner fascia, glass and logs (as described earlier in the manual).

Service person may also wish to remove the firebox to increase the work space within the heater.

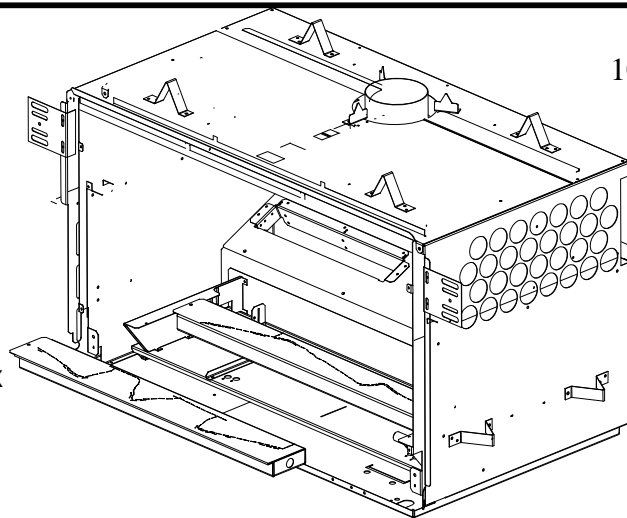

## Step Two:

Take out front two burners by removing the screws from the left hand end of the burner top face. Burners can then be lifted out.

## Step Three: (IB850 only)

Unscrew rear burner clamp bracket on left side.

Lift out the rear burner.

Step 3

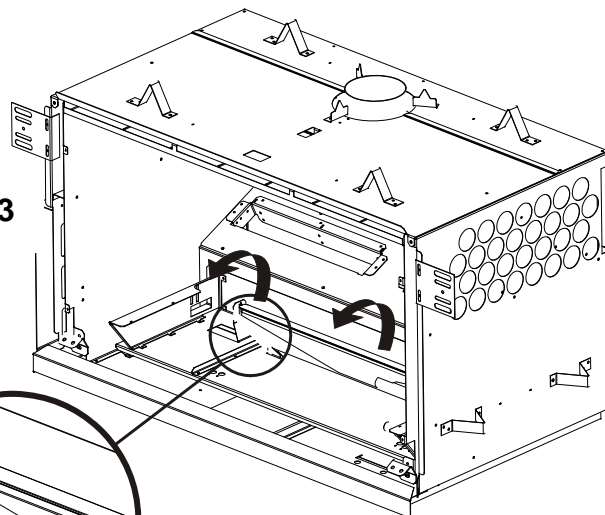

## Step Four:

Change the three jets (two jets in IB1100) with the jets supplied in kitset. Replace the rear burner and clamp bracket (IB850 only).

Replace front two burners with the burners supplied in kitset.

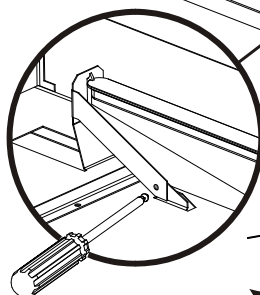

## Step Five:

Take the regulator spring out of the regulator by unscrewing the pressure adjustment knob completely. Swap regulator spring with the new spring that is supplied in conversion kitset. Replace adjustment screw.

Step 4

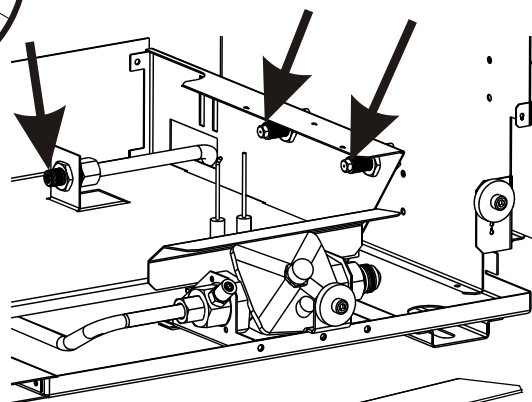

## Step Six:

Reset gas pressure as per instructions on page 6 of this manual.

Step 5

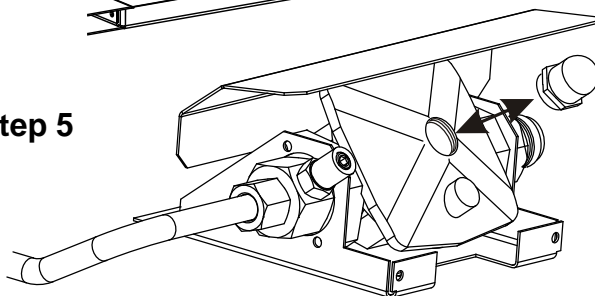

## Step Seven:

Cover the existing gas type label with the new gas type label supplied in kitset. Ensure serial number and date of manufacture are still visible. Write your name, company (if appropriate) and date of conversion on new label with permanent marker.

Replace firebox and fuel media.

Step 7

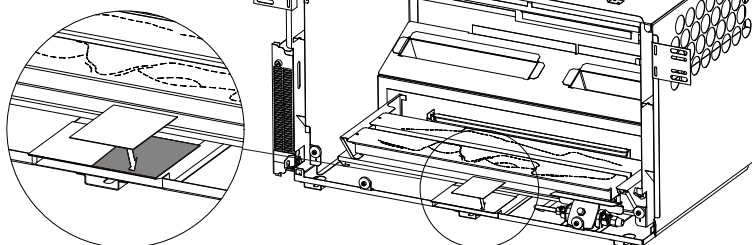

## Annual service procedure:

1. Isolate power to fire.
2. Remove front glass and clean inside of glass.
3. Remove logs and brush off any soot.
4. Remove burners and blow compressed air through the burner ports.
5. Remove jets and clean injector hole with solvent.
6. Remove firebox to give access to fan, brush and vacuum any dust build up from fan blades.
7. Vacuum any dust from the cavity that houses the fan and solenoid valves and from the ducts down each side of the heater that lead to this cavity.
8. If the gas piping includes a flexible hose connected to the regulator, check the hose for signs of wear (discolouration, loss of flexibility, cuts, worn covers, cracks, crushing, kinking, flattening or loose end fittings) and replace if worn, or more than five years old.
9. Test all joints for gas tightness.
10. Reassemble heater and check that operating pressure is correct. 2.3kPa Propane, 0.87kPa Natural Gas with all burners running.
11. Check glass & firebox tape and replace if necessary.
11. Check to make sure that flue system is intact and not in any way blocked. Check the flue draw with a smoke match to confirm there is no spillage from the draught diverter.
12. Trial heater with several start/stop cycles and trial fan-boost, flame effect only and thermostat modes to ensure that all modes function correctly.

# Wiring Diagram:

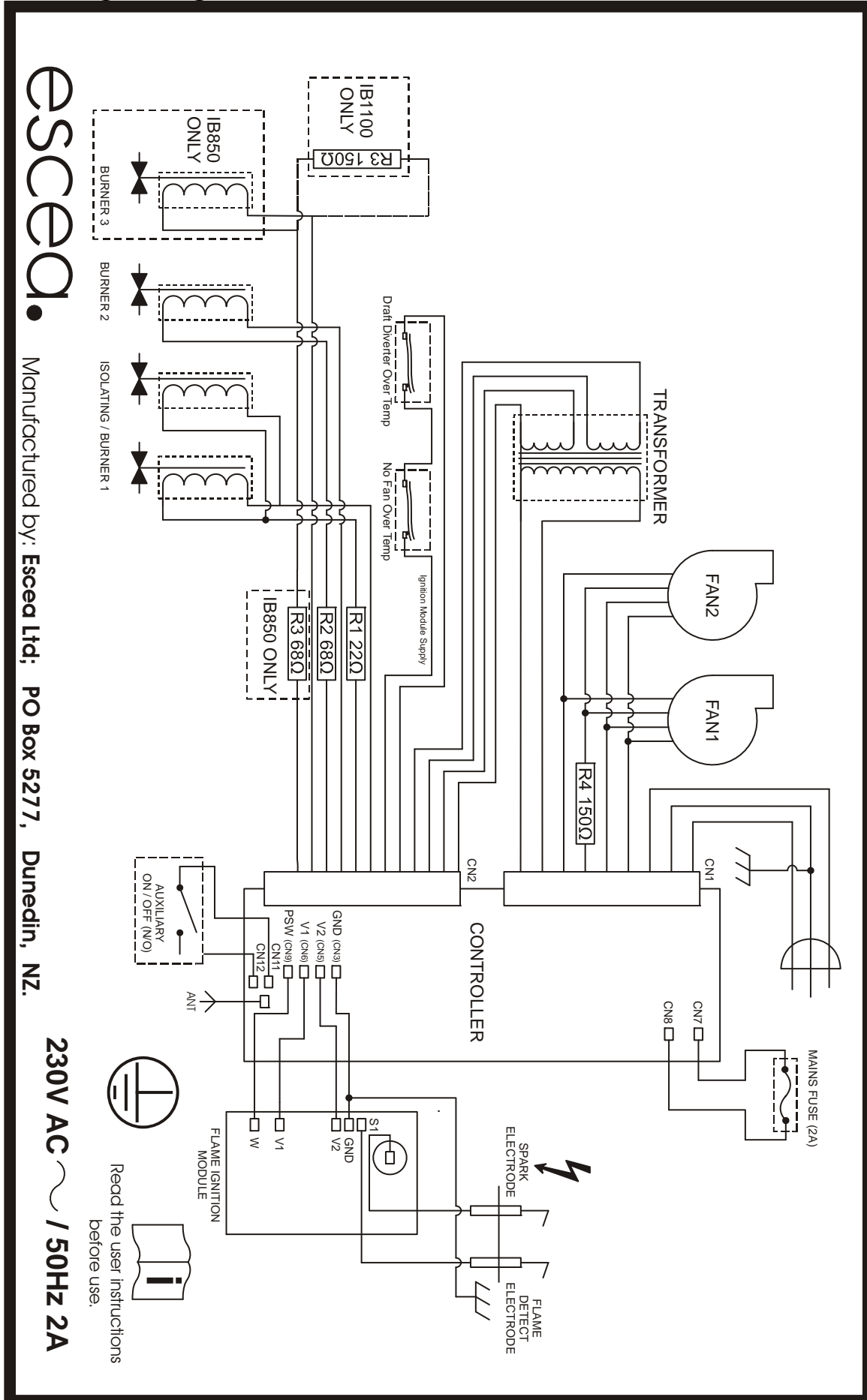

**escead.**

Manufactured by: **Escead Ltd.** PO Box 5277, Dunedin, NZ.

**230V AC** / **50Hz 2A**

Read the user instructions before use.